

---

---

## SYSTEMOLOGICAL BASES OF MANAGEMENT CONSULTING

Mikhail Bondarenko, Ekaterina Solovyova, Dmitriy Elchaninov

***Abstract:** The problem of management consulting for sustainable development organization support is discussed. The problem is formally described by means of systemological terms. The mathematical problem solving is considered. Practical use of the obtained results is outlined.*

***Keywords:** systemology, competitive intelligence, management consulting, sustainable development.*

***ACM Classification Keywords:** H. Information Systems - H.1 Models and Principles - H.1.1 Systems and Information Theory - General systems theory*

---

### Introduction

---

At the beginning we will discuss the sustainable development firm problem. Then the problem will formally described by means of systemological terms. The end of the paper will be devoted to mathematical problem solving. In conclusion we will outline practical use of the obtained results.

---

### Management Consulting for Sustainable Development

---

According to [Greiner and Metzger, 1983]: management consulting is an advisory service contracted for and provided to organizations by specially trained and qualified persons who assist, in an objective and independent manner, the client organization to identify **management problems**, analyze such problems, recommend solutions to these problems, and help, when requested, in the implementation of solutions.

Staffan Canback defines management consultants as those who provide general management advice within a **strategic, organizational or operational context** [Canback, 1998].

The contexts correspond with three management levels: strategic, tactical and operational. Strategic managers focus on long-term issues and emphasize the **survival, growth and overall effectiveness of the organization**. Tactical managers are responsible for translating the general goals and plans developed by strategic managers into more specific objectives and activities. Operational managers are directly involved with nonmanagement employees, implementing the specific plans developed with tactical managers. [Bateman and Snell, 1996].

Management is about helping a firm **survive and win** in competition with other companies. The firm gains competitive advantage by adopting **management approaches that satisfy people** (both inside and outside the firm) through cost competitiveness, high-quality products, speed and innovation [Lawler, 1992].

The aim of many companies is to jointly achieve the goals of economic growth and environmental quality in the long run by striving for **sustainable growth**. Sustainable growth is economic growth and development that meets the organization present needs without harming the ability of future generations to meet their needs [Rice, 1993].

The first thing managers can do to better understand environmental issues in their companies is to engage in systems thinking. Managers operate in organizations. An organization is a managed system designed and operated to achieve a specific set of objectives. Management scholars during the 1950s stepped back from the details of the organization to attempt to understand it as a whole system. These efforts were based on a general scientific approach called **systems theory** [Bertalanffy, 1972]. Business research is largely supported by business organizations that hope to achieve a competitive advantage [Cooper and Schindler, 2001].

In [Bossel, 1999] systems theory is used to identify the vital aspects of **sustainable development** and relevant indicators. Much work has been devoted to developing quantitative indicators of sustainable development [Parris

and Kates, 2003], [Segnestam, 2002], [Harris, 2000]. A great deal of literature concerned with understanding the core principles of sustainable development [Scottish Executive, 2006].

The aim of this paper is to show the efficiency of systemology [Melnikov, 1988] as a new concept for a system approach to solving **sustainable development** problems. The systemology was successfully used to solve a natural classification problem [Bondarenko et al, 2001] and business-systems modeling [Matorin and El'chaninov, 2002]. We hope that our results will be useful for sustainable business-systems modeling in management consulting process.

---

### Properties of a System

---

In connection with the fact that the terminology of the suggested systemological approach is not widely known, we will give a list of terms needed to understand the essentials of the present investigation [Melnikov, 1988], [Bondarenko et al, 1996].

**System** - an object the **properties** of which are determined by a function, which amounts to maintaining certain properties of an object at a higher level. This object is a **supersystem** in relation to the object (system) under consideration. Substance of a system - elements or **components** of the system, usually considered as subsystems. **Structure** of a system - the scheme of relations and interactions of a system's substance. **Property of a system** (valence) - **the ability to maintain** (in certain conditions) **relations of one type** and to prevent realization of relations of other types. Functional property of a system - a property that a system must possess in order to perform its functions; the ability to maintain relations (flows) on the basis of which interactions that are important for the supersystem occur between the system and surrounding systems. **Extensional** valence - a **property** realized in the form of a relation of the corresponding quality and constituting one of the varieties of reality. Free valence - a **property** only as an ability, not manifested in an existing relation and constituting one of the varieties of possibility (weak: **potential**, strong: **intentional**). External determinant of a system - the main reason for formation of a system: **the supersystem's functional need** for certain interactions of the system under consideration with other (surrounding) systems of this supersystem, which dictates the choice of the system's determinant.

---

### Ports of a System

---

A port of a system S is an input or an output of the system S. By means of ports the system S maintains relations with another systems. In other words system's ports correspond to system's properties. Extensional, intentional and potential ports of the system S are represented as figure 1 shows.

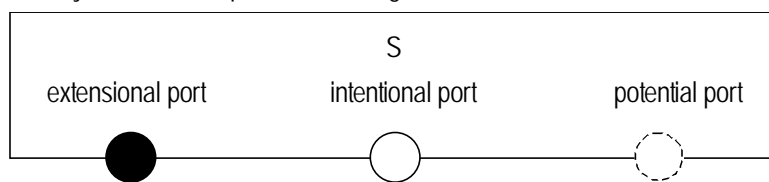

Fig. 1

An input port  $In$  is equal to an output port  $Out$  if the type of the port  $In$  is equal to the type of the port  $Out$  and vice versa. It means that if a system  $S_i$  has an output port  $Out_{i,x}$ , which is equal to an input port  $In_{j,y}$  of a system  $S_j$ , then systems  $S_i$  and  $S_j$  can be connected with each other as figure 2 shows.

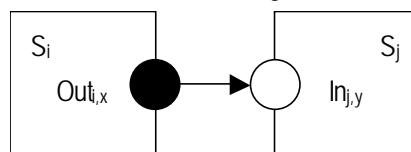

Fig. 2

Let  $In(S)$  is a set of the input ports of a system S and  $Out(S)$  is a set of the output ports of a system S.

An input port  $In_i$  of a system  $S$  is connected with an output port  $Out_j$  of the system  $S$  by means of component sequence  $\{S_q\}$  (see fig. 3) if:

1.  $In_i \in In(S_1)$ ;
2.  $Out(S_q) \cap In(S_{q+1}) \neq \emptyset, (q=1, \dots, Q-1)$ ;
3.  $Out_j \in Out(S_Q)$ .

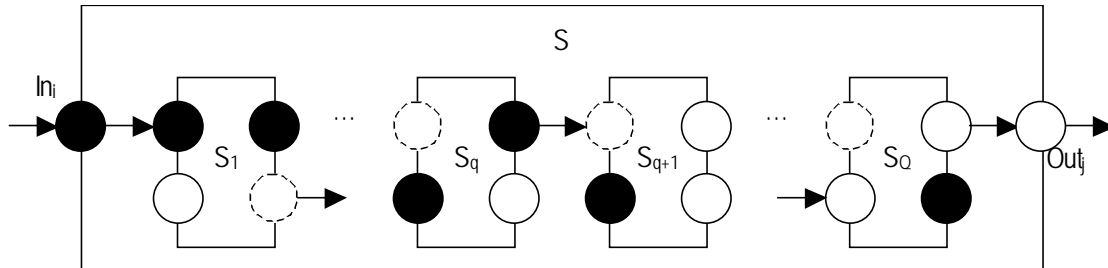

Fig. 3

Let this connection is denoted as follows:  $\langle In_i, S_1, \dots, S_q, S_{q+1}, \dots, S_Q, Out_j \rangle$ .

A subset  $B=\{B_{ij}\}$  of the set of components  $C=\{C_k\}$  is satisfied to a system  $S$  if each ports from the set  $In(S)$  is connected with some port from the set  $Out(S)$  by means of some subset of the subset  $B$  and vice versa, i.e.:

1.  $\forall In_i \in In(S) \exists Out_j \in Out(S) \exists D_i = \{D_{i,v}\} \subset B: \langle In_i, D_{i,1}, \dots, D_{i,v}, D_{i,v+1}, \dots, D_{i,v(Q)}, Out_j \rangle$ ;
2.  $\forall Out_j \in Out(S) \exists In_i \in In(S) \exists E_j = \{E_{j,w}\} \subset B: \langle In_i, E_{j,1}, \dots, E_{j,w}, E_{j,w+1}, \dots, E_{j,w(Q)}, Out_j \rangle$ .

**Formal Statement of Problem**

It is given:

1. External determinant of a system  $S$  - a set  $\{T_m\}$  of systems with free ports  $Out(T_m)$  and a set  $\{P_n\}$  of systems with free ports  $In(P_n)$ .
2. A set (library, package) of components  $C=\{S_k\}$ .

It is required to find a substance  $B \subset C$  of a system  $S$  and a structure of a system  $S$  such that  $\cup Out(T_m) \subset In(B)$  and  $\cup In(P_n) \subset Out(B)$  (see fig. 4).

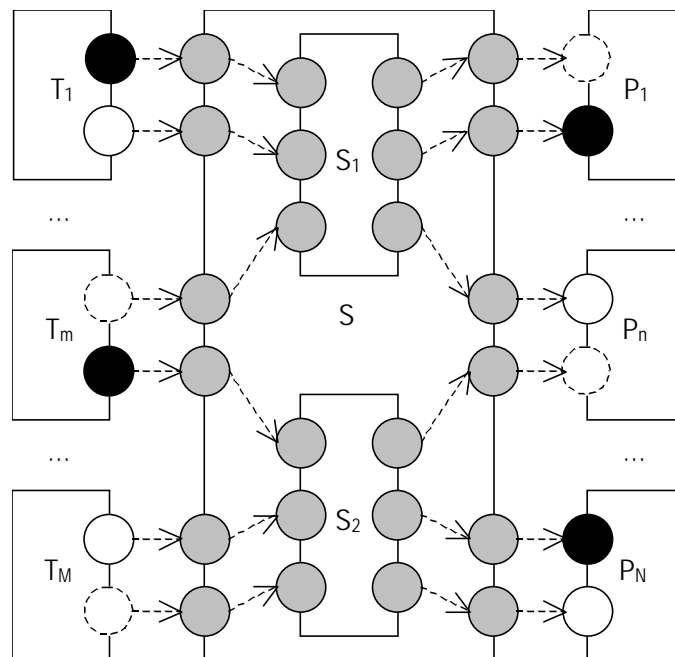

Fig. 4

**Problem Solving**

**Lemma 1.** The necessary conditions of being a set of components, which is satisfied to a system.

If a set of components  $\{S_u\}$  is satisfied to a system  $S$  then  $In(S) \subseteq \cup In(S_u)$  and  $Out(S) \subseteq \cup Out(S_u)$ .

The proof is illustrated by fig. 5.

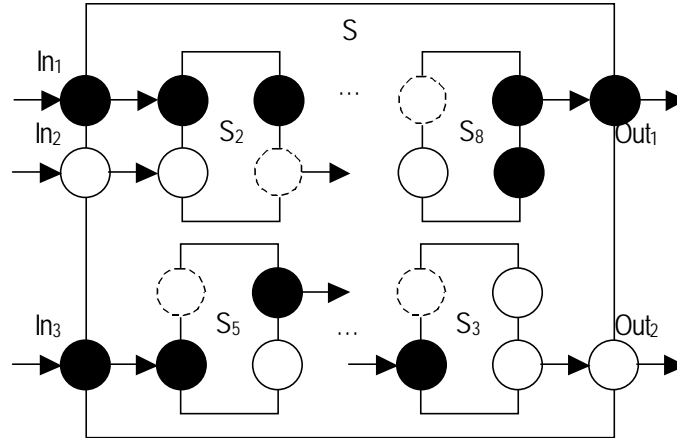

Fig. 5

**Lemma 2.** The sufficient conditions of excluding a component from a set of components, which is satisfied to a system.

If  $Out(S_k) \cap Out(S) = \emptyset$  and  $Out(S_k) \cap (\cup In(S_u)) = \emptyset$  or  $In(S_k) \cap In(S) = \emptyset$  and  $In(S_k) \cap (\cup Out(S_u)) = \emptyset$  then  $S_k \notin \{S_u\}$ , where the set of components  $\{S_u\}$  is satisfied to the system  $S$ .

The proof is illustrated by fig. 6.

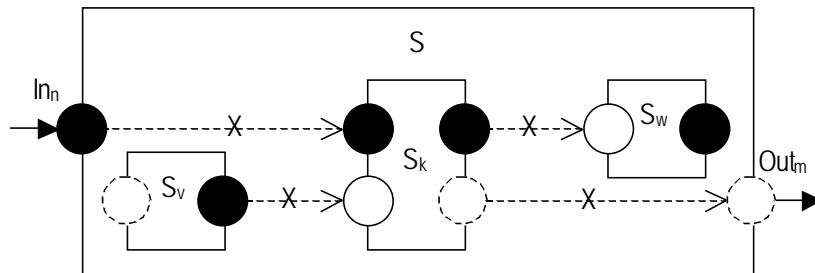

Fig. 6

**Lemma 3.** It is the consequence of lemma 2.

If  $C^*$  is a set of components, which is satisfied to the conditions of lemma 2, then any component  $S_u$  from a set  $C \setminus C^* = \{S_u\}$  is such that:

1.  $In(S) \cap In(S_u) \neq \emptyset$  or  $\exists S_v \in \{S_u\}: Out(S_u) \cap In(S_v) \neq \emptyset$ ;
2.  $Out(S) \cap Out(S_u) \neq \emptyset$  or  $\exists S_w \in \{S_u\}: Out(S_u) \cap In(S_w) \neq \emptyset$ .

The proof is trivial.

**Theorem.** The sufficient conditions of being a set of components, which is satisfied to a system.

If  $\exists \{S^r\}: \cup S^r \subseteq C$ , where  $S^r = \{S_{r,u}\}$ , are such that:

1.  $\forall S_{1,v} \in S^1 \Rightarrow (In(S) \cap In(S_{1,v}) \neq \emptyset) \wedge (In(S) \subseteq \cup In(S_{1,v}))$ ;
2.  $\forall S_{r,v} \in S^r \Rightarrow (\exists S_{r-1,v} \in S^{r-1}: Out(S_{r-1,v}) \cap In(S_{r,u}) \neq \emptyset) \wedge (\exists S_{r+1,w} \in S^{r+1}: Out(S_{r,u}) \cap In(S_{r+1,w}) \neq \emptyset)$ ,  $r=2, \dots, R-1$ ;
3.  $\forall S_{R,u} \in S^R \Rightarrow (Out(S) \cap Out(S_{R,w}) \neq \emptyset) \wedge (Out(S) \subseteq \cup Out(S_{R,w}))$ ,

then the set of components  $\cup S^r$  is satisfied to the system  $S$ .

The proof is left to the reader.

---

## Conclusion

---

Using the obtained results, one can make sustainable organization modeling. Lemma 1 can be used for selection of component libraries. Lemma 2 is useful for exclusion of components, which are unfit for system modeling. Lemma 3 describes all possible connections of components, which can be used for sustainable system modeling. Finally, the theorem is useful for assembling of complex multi-tier system configuration. The results can be applied in powerful modeling tool for analyzing, documenting and understanding complex business processes.

---

## Bibliography

---

- [Bateman and Snell, 1996] Bateman T.S., Snell S.A. Management: Building Competitive Advantage. Richard D. Irwin, 1996.
- [Bertalanffy, 1972] von Bertalanffy L. The History and Status of General Systems Theory. Academy of Management Journal, 1972, V.15, pp. 407-426.
- [Bondarenko et al, 1996] Bondarenko M.F., Matorin S.I., Solov'eva E.A. Analysis of Systemological Tools for Conceptual Modeling of Application Fields. Automatic Document and Mathematical Linguistics. Allerton Press, Inc., 1996, V.30, No.2, pp. 33-45.
- [Bondarenko et al, 2001] Bondarenko M.F., Elchaninov D.B., Solovyova E.A., Matorin S.I. Systemological and Mathematical Foundations of a Natural Classification. IJ ITA, 2001, V.8, No.3, pp. 151-157.
- [Bossel, 1999] Bossel H. Indicators for Sustainable Development: Theory, Method, Applications. A Report to the Balaton Group. International Institute for Sustainable Development: Winnipeg, Canada, 1999.
- [Canback, 1998] Canback S. The Logic of Management Consulting, Part 1. Journal of Management Consulting, 1998, V.10, No.2, pp.3-11.
- [Cooper and Schindler, 2001] Cooper D.R., Schindler P.S. Business Research Methods. New York: McGraw-Hill/Irwin, 2001.
- [Greiner and Metzger, 1983] Greiner L., Metzger R. Consulting to management. Englewood Cliffs, N.J.: Prentice-Hall, 1983.
- [Harris, 2000] Harris J.M. Basic Principles of Sustainable Development. Working Paper No. 00-04. Global Development and Environment Institute: Tufts University, USA, 2000.
- [Lawler, 1992] Lawler E.E. The Ultimate Advantage. San Francisco: Jossey-Bass, 1992.
- [Matorin and El'chaninov, 2002] Matorin S.I., El'chaninov D.B. Application of Pattern Theory in Formalization of Systemological UFO Analysis. Automatic Document and Mathematical Linguistics. Allerton Press, Inc., 2002, V.36, No.6, pp. 1-12.
- [Melnikov, 1988] Melnikov G.P. Systemology and Linguistic Aspects of Cybernetics. New York, Paris, Monterey, Tokyo, Melbourne: Gordon and Breach. 1988.
- [Parris and Kates, 2003] Parris T.M. and Kates R.W. Characterizing and Measuring Sustainable Development. Annual Review of Environment and Resources, 2003.
- [Rice, 1993] Rice F. Who Scores Best on the Environment. Fortune, July 26, 1993, pp. 114-122.
- [Scottish Executive, 2006] Sustainable Development: A Review of International Literature. Edinburgh: Scottish Executive, 2006. <http://www.scotland.gov.uk/Publications/2006/05/23091323/17>
- [Segnestam, 2002] Segnestam L. Indicators of Environment and Sustainable Development: Theories and Practical Experience. Environment Department Papers No. 89. The World Bank: Washington, DC, USA, 2002.

---

## Authors' Information

---

**Mikhail Bondarenko** - Rector, Kharkov National University of Radio Electronics, Lenin Ave., 14, Kharkov, 61166, Ukraine; e-mail: [rector@kture.kharkov.ua](mailto:rector@kture.kharkov.ua)

**Ekaterina Solovyova** - Social Informatics Department, Kharkov National University of Radio Electronics, Lenin Ave., 14, Kharkov, 61166, Ukraine; e-mail: [si@kture.kharkov.ua](mailto:si@kture.kharkov.ua)

**Dmitriy Elchaninov** - Social Informatics Department, Kharkov National University of Radio Electronics, Lenin Ave., 14, Kharkov, 61166, Ukraine; e-mail: [elchaninov@kture.kharkov.ua](mailto:elchaninov@kture.kharkov.ua)