

A LEARNING ALGORITHM FOR FORECASTING ADAPTIVE WAVELET-NEURO-FUZZY NETWORK

Yevgeniy Bodyanskiy, Iryna Pliss, Olena Vynokurova

Abstract: *The architecture of forecasting adaptive wavelet-neuro-fuzzy-network and its learning algorithm for the solving of nonstationary processes forecasting tasks are proposed. The learning algorithm is optimal on rate of convergence and allows to tune both the synaptic weights and dilations and translations parameters of wavelet activation functions. The simulation of developed wavelet-neuro-fuzzy network architecture and its learning algorithm justifies the effectiveness of proposed approach.*

Keywords: *wavelet, adaptive wavelet-neuro-fuzzy network, recurrent learning algorithm, forecasting, emulation.*

ACM Classification Keywords: *I.2.6 Learning – Connectionism and neural nets*

Introduction

At present time the neuro-fuzzy systems have been an increasingly popular technique of soft computing [1-4] successfully applied for the processing of information containing complex nonlinear regularities and distortions of all kinds. These systems combine the linguistic interpretability and the approximation properties of the fuzzy inference systems [5, 6] with the learning and universal approximation capabilities of artificial neural networks [7, 8]. This means, that they can be used in forecasting of stochastic and chaotic signals and sequences with complex nonlinear trends and nonstationary parameters, described by the difference nonlinear autoregression equations (NAR) in the form

$$x(k) = F(x(k)) + \xi(k),$$

where $x(k)$ is a signal value in k -th instant of discrete time $k = 0, 1, 2, \dots$, $X(k) = (x(k-1), x(k-2), \dots, x(k-n))^T$ is $(n \times 1)$ the prehistory vector, which determines present state $x(k)$, $F(\bullet)$ is an arbitrary nonlinear function, unknown in the general case, $\xi(k)$ is a stochastic disturbance with unknown characteristics but with bounded second moment.

Along with the neuro-fuzzy systems for processing the signals of all kinds, the wavelet transform has been an increasingly popular technique [9-11] which provides a compact local signal representation in both time and frequency domain. At the turn of the artificial neural network and wavelets theories the wavelet neural networks have evolved for the analysis of nonstationary processes with considerably nonlinear trends [12-18].

The natural step is to combine the transparency and the interpretability of fuzzy inference systems, powerful approximation and learning capabilities of artificial neural networks and compact description and the flexibility of wavelet transform in the context of hybrid systems of computational intelligence, which further we shall call as the adaptive wavelet-neuro-fuzzy networks (AWNFN).

The key point, defining effectiveness of such systems, is the choice of learning algorithm, which is usually based on the gradient procedures of the accepted criterion minimization. Combination of the gradient optimization with the error backpropagation essentially reduces the rate of learning hybrid systems [19] and leads to necessity of using rather large training samples. In the case when the data processing has to be carried out in real time,

forecasted sequence is nonstationary and distorted, conventional gradient descent learning algorithms (let alone genetic algorithms) appeared to be ineffective.

The paper is devoted to the tasks of synthesis of forecasting adaptive wavelet-neuro-fuzzy network, which has higher rate of learning in comparison with systems using conventional backpropagation gradient algorithm.

Architecture of the forecasting adaptive wavelet-neuro-fuzzy network

Let us introduce into consideration the five-layers architecture, shown on fig. 1, someway similar to the well-known ANFIS [2] which is in turn the learning system of Takagi-Sugeno-Kang fuzzy inference [20, 21].

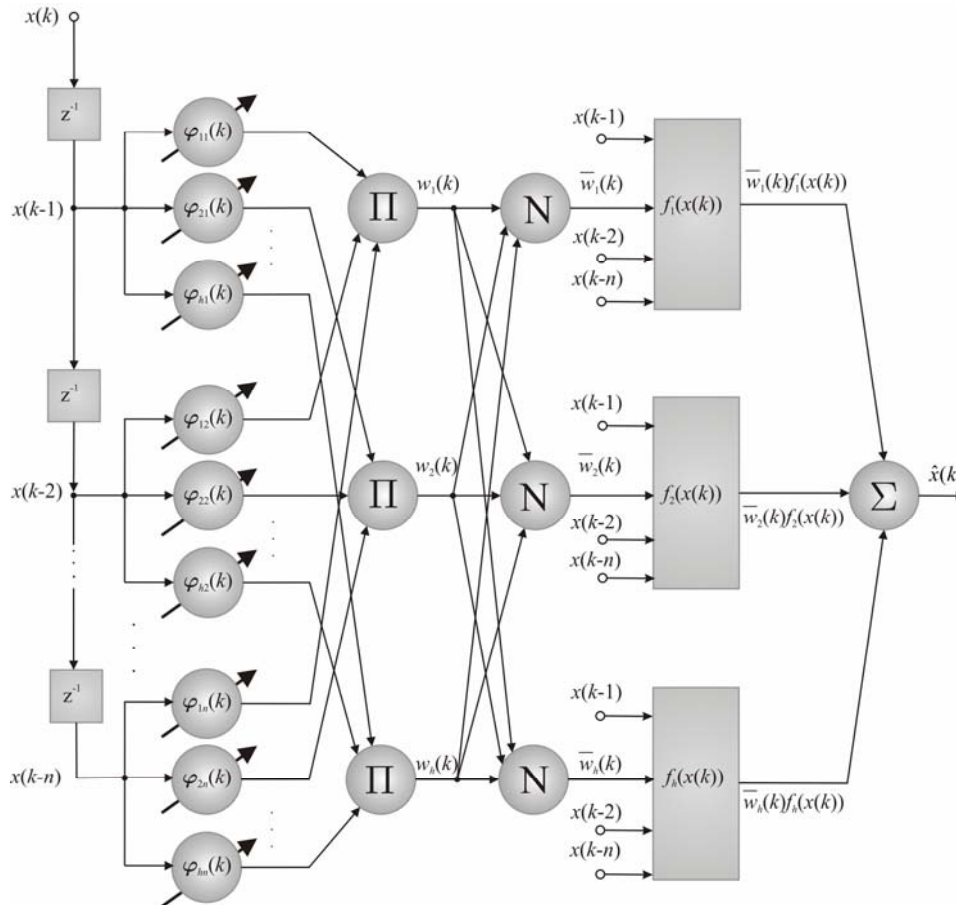

Fig. 1 – Forecasting adaptive wavelet-neuro-fuzzy network

The input layer of the architecture is formed of the time-delay elements z^{-1} ($z^{-1}x(k) = x(k-1)$) and under the input of current signal value $x(k)$ the prehistory vector $X(k) = (x(k-1), x(k-2), \dots, x(k-n))^T$ is formed as an output of this layer.

The first hidden layer unlike the neuro-fuzzy systems is formed not of conventional non-negative membership functions, but of hn wavelets (h wavelets for each input) $\varphi_{ji}(x(k-i)) = \varphi_{ji}(x(k-i), c_{ji}, \sigma_{ji}) = \varphi_{ji}(k)$ with $2hn$ tuning parameters of dilation (center) c_{ji} and translation (width) σ_{ji} .

Various kinds of analytical wavelets can be used as the activation functions in adaptive wavelet-neuro-fuzzy network, for example: Morlet wavelets, "Mexican hat" wavelets, Polywog wavelets, Rasp wavelets [12], the generator of analytic wavelets [22], the triangular wavelets [23].

Here it can be noticed, that the oscillation character of wavelet function doesn't contradict the unipolarity of membership functions as negative values φ_{ji} can be interpreted in terms of the small membership or nonmembership levels [24, 25].

The second hidden layer performs the operation similar to computing of fuzzy T -norm

$$w_j(k) = \prod_{i=1}^n \varphi_{ji}(x(k-i)), \quad j=1,2,\dots,h,$$

after that the normalization is performed in the third hidden layer

$$\bar{w}_j(k) = \frac{w_j(k)}{\sum_{j=1}^h w_j(k)} = \frac{\prod_{i=1}^n \varphi_{ji}(x(k-i))}{\sum_{j=1}^h \prod_{i=1}^n \varphi_{ji}(x_i(k-i))},$$

providing fulfillment of the condition

$$\sum_{j=1}^h \bar{w}_j(k) = 1.$$

The fourth hidden layer performs an operation similar to computing of the consequent in the fuzzy inference systems. The most often used function $f_j(x(k))$ in fuzzy inference systems is linear form (in our case local autoregression model):

$$f_j(X(k)) = p_{j0} + \sum_{i=1}^n p_{ji}x(k-i).$$

In this case in the fourth layer signal values are computed

$$\bar{w}_j(k)(p_{j0} + \sum_{i=1}^n p_{ji}x(k-i)) = \bar{w}_j(k)p_j^T \bar{X}(k),$$

where $\bar{X}(k) = (1, X^T(k))^T$, $p_j = (p_{j0}, p_{j1}, \dots, p_{jn})^T$, and $h(n+1)$ parameters p_{ji} , $j=1,2,\dots,h$, $i=0,1,2,\dots,n$ are to be determined.

And at last output signal (forecast $\hat{x}(k)$) of network is computed in the fifth output layer

$$\hat{x}(k) = \sum_{j=1}^h \bar{w}_j(k) f_j(X(k)) = \sum_{j=1}^h \frac{w_j(k)}{\sum_{j=1}^h w_j(k)} f_j(X(k)) = \sum_{j=1}^h \frac{\prod_{i=1}^n \varphi_{ji}(x_i(k-i), c_{ji}, \sigma_{ji})}{\sum_{j=1}^h \prod_{i=1}^n \varphi_{ji}(x_i(k-i), c_{ji}, \sigma_{ji})} f_j(X(k)),$$

which, introducing the variables vectors $f(X(k)) = (\bar{w}_1(k), \bar{w}_1(k)x(k-1), \dots, \bar{w}_1(k)x(k-n), \bar{w}_2(k), \bar{w}_2(k)x(k-1), \dots, \bar{w}_2(k)x(k-n), \dots, \bar{w}_h(k), \bar{w}_h(k)x(k-1), \dots, \bar{w}_h(k)x(k-n))^T$, $p = (p_{10}, p_{11}, \dots, p_{1n}, p_{20}, p_{21}, \dots, p_{2n}, p_{h0}, p_{h1}, \dots, p_{hn})^T$ of dimensionality $h(n+1)$, can be rewritten in the compact form

$$\hat{x}(k) = p^T f(X(k)).$$

The tunable parameters of this network are located only in the first and fourth hidden layers. These are $2hn$ wavelets parameters c_{ji} and σ_{ji} , and $h(n+1)$ parameters of the linear local autoregression models p_{ji} . Namely they must be determined during the learning process.

The learning of forecasting adaptive wavelet-neuro-fuzzy network

As far as tunable vector of parameters p is contained in the network description linearly, for its refinement any of the algorithms used in adaptive identification [26] will operate, primarily the exponentially weighted recurrent least squares method (this method is the second order optimization procedure and has both filtering and following properties) in the form

$$\begin{cases} p(k+1) = p(k) + \frac{P(k)(x(k) - p^T(k)f(X(k)))}{\alpha + f^T(X(k))P(k)f(X(k))} f(X(k)), \\ P(k+1) = \frac{1}{\alpha} \left(P(k) - \frac{P(k)f(X(k+1))f^T(X(k+1))P(k)}{\alpha + f^T(X(k+1))P(k)f(X(k+1))} \right) \end{cases} \quad (1)$$

where $x(k) - p^T(k)f(x(k)) = x(k) - \hat{x}(k) = e(k)$ is the forecasting error, $0 < \alpha \leq 1$ is the out-dated information forgetting factor; optimal on operation rate one-step gradient Kaczmarz algorithm [27, 28], having the following properties

$$p(k+1) = p(k) + \frac{x(k) - p^T(k)f(X(k))}{f^T(X(k))f(X(k))} f(X(k)), \quad (2)$$

or Goodwin-Ramadge-Caines algorithm [29]

$$\begin{cases} p(k+1) = p(k) + r^{-1}(k)(x(k) - p^T f(X(k)))f(X(k)), \\ r(k+1) = r(k) + \|f(X(k+1))\|^2, \end{cases} \quad (3)$$

which is the stochastic approximation procedure.

Here it should be mentioned, that exponentially weighted recurrent least squares method (1), having filtering and following properties, can be unstable under small values of parameter α ; convergence of the algorithm (2) under the intensive disturbance ξ is disrupted, and stochastic approximation procedures, including (3), operate only in the stationary conditions.

For tuning of the first hidden layer parameters in AWNFN backpropagation learning algorithm based on the chain rule of differentiation and gradient descend optimization of local criterion

$$E(k) = \frac{1}{2} e^2(k) = \frac{1}{2} (x(k) - \hat{x}(k))^2$$

is used.

In the general case learning procedure in this layer has the form

$$\begin{cases} c_{ji}(k+1) = c_{ji}(k) - \eta_c(k) \frac{\partial E(k)}{\partial c_{ji}(k)}, \\ \sigma_{ji}(k+1) = \sigma_{ji}(k) - \eta_\sigma(k) \frac{\partial E(k)}{\partial \sigma_{ji}(k)}, \end{cases}$$

and its properties are completely determined by the learning rate parameter $\eta_c(k)$, $\eta_\sigma(k)$, selected according to the empirical reasons. It should be noticed that if the parameters of the fourth layer can be tuning most rapidly, the operation rate is lost in the first layer.

Increasing of the convergence rate can be achieved with more complex than gradient procedures, such as Hartley [30] or Marquardt [31] algorithms which can be written in general form [32]

$$\Phi(k+1) = \Phi(k) + \lambda(J(k)J^T(k) + \eta I)^{-1} J(k)e(k), \quad (4)$$

where $\Phi(k) = (c_{11}(k), \sigma_{11}^{-1}(k), c_{21}(k), \sigma_{21}^{-1}(k), \dots, c_{ji}(k), \sigma_{ji}^{-1}(k), \dots, c_{hn}(k), \sigma_{hn}^{-1}(k))^T$ is the $(2hn \times 1)$ tunable parameter vector (at that for the computation complexity reduction it includes not the width parameter σ_{ji} , but its inverse value σ_{ji}^{-1}), $J(k)$ is the $(2hn \times 1)$ gradient vector of output signal $\hat{x}(k)$ on the tunable parameters, I is the $(2hn \times 2hn)$ identity matrix, η is a scalar regularizing parameter, λ is the positive scalar gain.

To compute elements of gradient vector

$$J(k) = \left(\frac{\partial \hat{x}(k)}{\partial c_{11}}, \frac{\partial \hat{x}(k)}{\partial \sigma_{11}^{-1}}, \frac{\partial \hat{x}(k)}{\partial c_{21}}, \frac{\partial \hat{x}(k)}{\partial \sigma_{21}^{-1}}, \dots, \frac{\partial \hat{x}(k)}{\partial c_{ji}}, \frac{\partial \hat{x}(k)}{\partial \sigma_{ji}^{-1}}, \dots, \frac{\partial \hat{x}(k)}{\partial c_{hn}}, \frac{\partial \hat{x}(k)}{\partial \sigma_{hn}^{-1}} \right)^T$$

the chain rule can be used, at that

$$\begin{cases} \frac{\partial \hat{x}(k)}{\partial c_{ji}} = \frac{\partial \hat{x}(k)}{\partial \bar{w}_j} \cdot \frac{\partial \bar{w}_j}{\partial w_j} \cdot \frac{\partial w_j}{\partial \varphi_{ji}} \cdot \frac{\partial \varphi_{ji}}{\partial c_{ji}} = f_j(X(k)) \bar{w}_j(k) (1 - \bar{w}_j(k)) \frac{1}{\varphi_{ji}(x_i(k), c_{ji}, \sigma_{ji}^{-1})} \cdot \frac{\partial \varphi_{ji}}{\partial c_{ji}}, \\ \frac{\partial \hat{x}(k)}{\partial \sigma_{ji}^{-1}} = \frac{\partial \hat{x}(k)}{\partial \bar{w}_j} \cdot \frac{\partial \bar{w}_j}{\partial w_j} \cdot \frac{\partial w_j}{\partial \varphi_{ji}} \cdot \frac{\partial \varphi_{ji}}{\partial \sigma_{ji}^{-1}} = f_j(X(k)) \bar{w}_j(k) (1 - \bar{w}_j(k)) \frac{1}{\varphi_{ji}(x_i(k), c_{ji}, \sigma_{ji}^{-1})} \cdot \frac{\partial \varphi_{ji}}{\partial \sigma_{ji}^{-1}}. \end{cases}$$

where $\partial \varphi_{ji} / \partial c_{ji}$, $\partial \varphi_{ji} / \partial \sigma_{ji}^{-1}$ is partial derivatives of concrete wavelet activation function.

To reduce the computational complexity of the learning algorithm we can use the matrix inversion lemma in the form

$$(JJ^T + \eta I)^{-1} = \eta^{-1} I - \frac{\eta^{-1} I J J^T \eta^{-1} I}{1 + J^T \eta^{-1} I J},$$

using which it is easy to obtain the relation

$$\lambda (JJ^T + \eta I)^{-1} J = \lambda \frac{J}{\eta + \|J\|^2}.$$

Substituting this relation to the algorithm (4), we obtain first hidden layer parameters learning algorithm in the form

$$\Phi(k+1) = \Phi(k) + \lambda \frac{J(k)e(k)}{\eta + \|J(k)\|^2}. \quad (5)$$

It is easy to see, that algorithm (5) is the nonlinear additive-multiplicative modification of Kaczmarz algorithm, and under $\lambda = 1$, $\eta = 0$ coincides with it structurally.

To provide the filtering properties to the learning algorithm (5) let us introduce additional tuning procedure of the regularizing parameter η in the form [33, 34, 35]

$$\begin{cases} \Phi(k+1) = \Phi(k) + \lambda \frac{J(k)e(k)}{\eta(k)}, \\ \eta(k+1) = \alpha \eta(k) + \|J(k+1)\|^2. \end{cases} \quad (6)$$

If $\alpha = 0$, then this procedure coincides with (5) and has the highest rate of convergence, and if $\alpha = 1$, then this procedure obtains properties of stochastic approximation, and serves as generalization of procedure (3) in the nonlinear case.

Here it should be noticed, that the algorithm (6) is stable at any value of forgetting factor α , what favorably differs it from the exponentially weighted recurrent least squares method (1). As a result this procedure can be used too in the form

$$\begin{cases} p(k+1) = p(k) + \lambda_p \eta_p^{-1}(k)(x(k) - p^T(k)f(X(k)))f(X(k)), \\ \eta_p(k+1) = \alpha \eta_p(k) + \|f(x(k))\|^2 \end{cases} \quad (7)$$

for the fourth layer parameters tuning. One can notice close relation of the algorithms (1) and (Error! Reference source not found.), as

$$\eta^{-1}(k) = \text{Tr}P(k).$$

However algorithm (Error! Reference source not found.) is much simpler in the computing implementation and easily reconstructs its properties from the most following to the most filtering ones.

Simulation results

To demonstrate the effectiveness of the proposed adaptive wavelet-neuro-fuzzy-network and its learning algorithm (6), (7), AWNFN was trained to forecast the Mackey-Glass chaotic time series. Forecasting of the Mackey-Glass time series is a standard test, widely used to evaluate and compare the performance of neural and neuro-fuzzy systems for nonlinear system modeling and time series forecasting. The Mackey-Glass time series is generated by the time-delay differential equation [36]

$$\dot{x}(t) = \frac{0.2x(t-\tau)}{1+x^{10}(t-\tau)} - 0.1x(t). \quad (8)$$

The values of the time series (8) were obtained at each integer point by means of the fourth-order Runge-Kutta method. The time step used in this method was set 0.1, while initial condition $x(0)=1.2$, delay $\tau=17$ and $x(t)$ was obtained for $t=0\dots51000$. The values $x(t-18), x(t-17), x(t-6), x(t)$ were used to forecast $x(t+6)$. In the online mode of learning, AWNFN was trained with procedure (6), (7) for 50000 iteration (50000 training samples for $t=118, \dots, 50117$). The parameters of the learning algorithm were $\alpha=0.95$, $\lambda_p=2$, $\lambda=1$. Initial values were $\eta(0)=1$ and $\eta_p(0)=10000$. After 50000 iterations the training was stopped, and the next 500 points for $t=50118\dots50617$ were used as the testing data set to compute forecast. As the activation function "Maxican hat" wavelet is used. Initial values of synaptic weights were generated in a random way from -0.1 to $+0.1$.

The root mean-square error (RMSE) was used as criterion for the quality of forecasting

$$RMSE = \frac{1}{N} \sum_{k=1}^N (x(k) - \hat{x}(k))^2.$$

Fig. 5 shows the results of chaotic time series forecasting. The two curves, representing the actual (dot line) and forecasting (solid line) values, are almost indistinguishable.

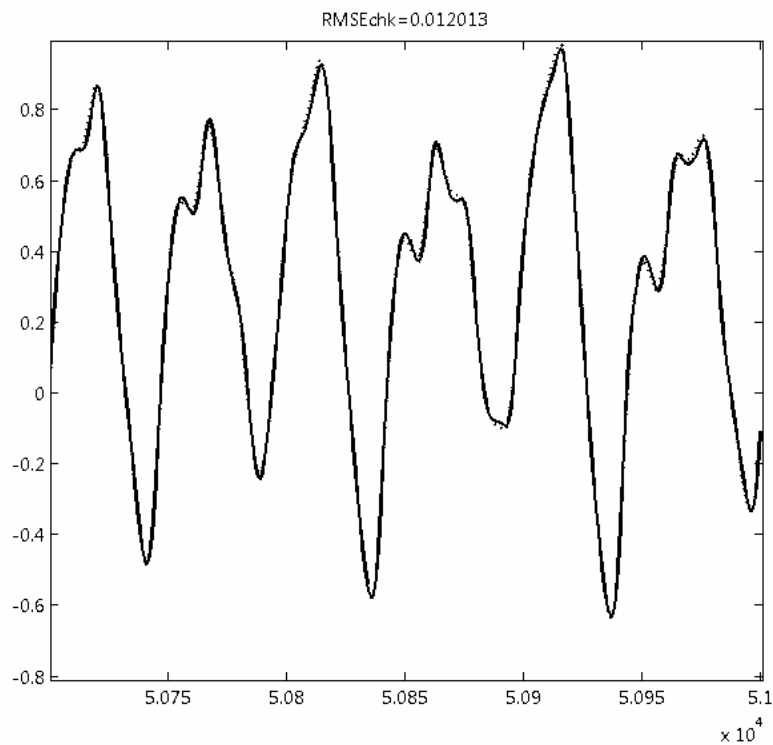

Fig. 5 – Forecasting of Mackey-Glass chaotic time series using adaptive wavelet-neuro-fuzzy network (online-learning, 50000 iteration)

Table 1 shows results of forecasting process on the basis of the adaptive wavelet-neuro-fuzzy-network compared the results of forecasting process on the basis of standard ANFIS with the backpropagation learning algorithm.

Table 1: The results of chaotic time series forecasting

Neural network/ Learning algorithm	RMSE
Adaptive wavelet-neuro-fuzzy-network / Proposed learning algorithm (6), (7)	0.0120
Backpropagation ANFIS	0.2312

Thus as it can be seen from experimental results the proposed forecasting adaptive wavelet-neuro-fuzzy-network with the learning algorithm (6), (7) having the same number of adjustable parameters ensures the best quality of forecast and high learning rate in comparison with conventional ANFIS architecture.

Conclusions

Computationally simple learning algorithms for the adaptive wavelet-neuro-fuzzy network in the forecasting of nonlinear nonstationary signals tasks are proposed. The simulation of developed approach justifies the effectiveness of AWFNFN using for solving wide category of emulation, forecasting and diagnostics problems.

Bibliography

- [1]. Jang J.-S. R. *Neuro-Fuzzy Modeling: Architectures, Analyses and Applications*. Berkeley, CA: University of California. 1992, 155 p.
- [2]. Jang J.-S. R. ANFIS: Adaptive network-based fuzzy inference systems. *IEEE Trans. on Systems, Man, and Cybernetics*. 23, 1993, P. 665-685.
- [3]. Jang J.-S. R., Sun C.-T. Neuro-fuzzy modeling and control. *Proc. IEEE*. 83 (3), 1995, P. 378-406.
- [4]. Jang J.-S. R., Sun C.-T., Muzutani E. *Neuro-Fuzzy and Soft Computing: A Computational Approach to Learning and Machine Intelligence*. Upper Saddle River, N.J.: Prentice Hall, Inc., 1997, 614 p.
- [5]. Kosko B. Fuzzy systems as universal approximators. *Proc. 1-st IEEE Int. Conf. on Fuzzy Systems*. San Diego, CA. 1992, P. 1153-1162.
- [6]. Kreinovich V., Mouzouris Y. C., Nguen H. T. Fuzzy rule based modeling as a universal approximation tool. In "Fuzzy Systems: Modeling and Control". Eds.: H. T. Nguen, M. Sugeno. Boston: Kluwer Academic Publishers. 1998, P. 135-195.
- [7]. Hornik K., Stinchcombe M., White H. Multilayer feedforward networks are universal approximators. *Neural Networks*. 2, 1982, P. 359-366.
- [8]. Scarcelli F., Tsoi A. S. Universal approximation using feedforward neural networks: a survey of some existing methods and some new results. *Neural Networks*. 11, 1998, P. 15-37.
- [9]. Chui C. K. *An Introduction to Wavelets*. New York: Academic. 1992, 264 p.
- [10]. Daubechies I. *Ten Lectures on Wavelets*. Philadelphia, PA: SIAM. 1992, 228 p.
- [11]. Meyer Y. *Wavelets: Algorithms and Applications*. Philadelphia, PA: SIAM. 1993, 133 p.
- [12]. Lekutai G., VanLandingham H. F. Self-tuning control of nonlinear systems using neural network adaptive frame wavelets. *Proc. IEEE Int. Conf. on Systems, Man and Cybernetics*. Piscataway, N.J. 2, 1997, P. 1017-1022.
- [13]. Billings S. A., Wei H.-L. A new class of wavelet networks for nonlinear system identification. *IEEE Trans. on Neural Networks*. 16 (4), 2005, P. 862-874.
- [14]. Zhang Q. H., Benveniste A. Wavelet networks. *IEEE Trans. on Neural Networks*. 3 (6), 1992, P. 889-898.
- [15]. Oussar Y., Dreyfus G. Initialization by selection for wavelet network training. *Neurocomputing*. 34, 2000, P. 131-143.
- [16]. Zhang J., Walter G. G., Miao Y., Lee W. N. W. Wavelet neural networks for function learning. *IEEE Trans. on Signal Process*. 43(6), 1995, P. 1485-1497.
- [17]. Zhang Q. H. Using wavelet network in nonparametric estimation. *IEEE Trans. on Neural Networks*. 8 (2), 1997, P. 227-236.
- [18]. Bodyanskiy Ye., Lamonova N., Pliss I., Vynokurova O. An adaptive learning algorithm for a wavelet neural network. *Blackwell Synergy: Expert Systems*. 22 (5), 2005, P. 235-240.
- [19]. Avci E., Turkoglu I., Poyraz M. Intelligent target recognition based on wavelet adaptive network based fuzzy inference system. *Lecture Notes on Computer Science*. Berlin-Heidelberg: Springer-Verlag, 3522, 2005, P. 594-603.
- [20]. Takagi T., Sugeno M. Fuzzy identification of systems and its applications to modeling and control. *IEEE Trans. on Systems, Man, and Cybernetics*. 15, 1985, P. 115-132.
- [21]. Sugeno M., Kang G. T. Structure identification of fuzzy model. *Fuzzy Sets and Systems*, 28, 1998, P. 15-33.
- [22]. Vynokurova O., Lamonova N., Pliss I. Analytic wavelets generator. *Problemy Bioniki*, 60, 2004, P. 104-109. (in Russian)
- [23]. Bodyanskiy Ye., Vynokurova O. Variable form of triangular wavelet in the wavelet neural networks. *Proc. of 13th International Conference on Automatic Control "Automatics-2006"*, Vinnica, 2006, P. 393. (in Russian)
- [24]. Mitaim S., Kosko B. What is the best shape for a fuzzy set in function approximation? *Proc. 5th IEEE Int. Conf on Fuzzy Systems "Fuzz-96"*, 2, 1996, P. 1237-1213.

- [25]. Mitaim S., Kosko B. Adaptive joint fuzzy sets for function approximation. Proc. Int. Conf. on Neural Networks "ICNN-97", 1997, P. 537-542.
- [26]. Ljung L. System Identification: Theory for the user. PTR Prentice Hall, Upper Saddle River, N.J., 1999
- [27]. Kaczmarz S. Angenaeherte Ausloesung von Systemen linearer Gleichungen. Bull. Int. Acad. Polon. Sci., Let. A , 1973, S. 355-357.
- [28]. Kaczmarz S. Approximate solution of systems of linear equations. Int. J. Control, 53, 1993, P. 1269-1271.
- [29]. Goodwin Y. C., Ramadge P. J., Caines P. E. A globally convergent adaptive predictor. Automatica, 17, 1981, P. 135-140.
- [30]. Hartley H. The modified Gauss-Newton method for the fitting of nonlinear regression functions of least squares. Technometrics, 3, 1961, P. 269-280.
- [31]. Marquardt D. An algorithm for least squares estimation of nonlinear parameters. SIAM J. Appl. Math., 11, 1963, P. 431-441.
- [32]. Bodyanskiy Ye. Adaptive identification algorithm of nonlinear control object. Automatic control system and devices of automatic, Kharkiv: Vyscha shk., 81, 1987, P. 43-46. (in Russian)
- [33]. Bodyanskiy Ye., Pliss I., Solovyova T. Multistage optimal predictors multidimensional nonstationary stochastic process. Docl. AN USSR. 12, 1986, P. 41-49.
- [34]. Bodyanskiy Ye., Kolodyazhniy V., Stephan A. An adaptive learning algorithm for a neuro-fuzzy network. Ed. by B. Reusch "Computational Intelligence. Theory and Applications." Berlin-Heidelberg-New York: Springer-Verlag, 2001, P. 68-75.
- [35]. Bodyanskiy Ye., Kolodyazhniy V., Otto P. A new learning algorithm for a forecasting neuro-fuzzy network. Integrated Computer-Aided Engineering. Amsterdam: IOS Press, 10 (4), 2003, P. 399-409.
- [36]. Mackey M. C., Glass L. Oscillation and chaos in physiological control systems. Science, 1977, 197, P. 287-289

Authors' Information

Bodyanskiy Yevgeniy - Doctor of Technical Sciences, Professor of Artificial Intelligence Department and Scientific Head of the Control Systems Research Laboratory, Kharkiv National University of Radio Electronic, Lenina av. 14, Kharkiv, Ukraine 61166, Tel +380577021890, bodya@kture.kharkov.ua

Pliss Iryna - Candidate of Technical Sciences (equivalent Ph.D.), Senior Researcher, Leading Researcher of the Control Systems Research Laboratory, Kharkiv National University of Radio Electronic, Lenina av. 14, Kharkiv, Ukraine, 61166, Tel +380577021890, pliss@kture.kharkov.ua

Vynokurova Olena - Candidate of Technical Sciences (equivalent Ph.D.), Senior Researcher of the Control Systems Research Laboratory, Kharkiv National University of Radio Electronic, Lenina av. 14, Kharkiv, Ukraine, 61166, Tel +380577021890, vinokurova@kture.kharkov.ua