

CONSTRUCTION OF THE MODEL OF INDIVIDUAL MULTIFACTOR ASSESSMENT BY MEANS OF GMDH-NEURAL NETWORK

Eduard Petrov, Konstantin Petrov, Tatyana Chaynikova

Abstract: *This paper deals with one of the approaches to the solution of the problem of structurally-parametric identification of the model of individual multifactor assessment which is based on the use of artificial GMDH-neural network. The use of artificial neural network (ANN) methodology opens the prospects for paralleling of the model synthesis process and realizing computational procedure of linear complexity.*

Keywords: *comparative identification, GMDH – neural network, model of multifactor assessment, Kolmogorov-Gabor polynomial.*

Introduction

Decision-making process is defined as a particular kind of mental work, composed of one or several alternate solutions from some admissible set.

General problem of decision making can be divided into the following steps: goal formation and analysis; definition of probable ways set for the goal achievement (the problem of admissible solutions set formation); formation of assessment allowing to compare admissible solutions with each other in quality (assessment problem); admissible set ranking and extremal solution selection (optimization problem).

Without diminishing the importance of the above mentioned steps it should be noted that assessment is one of the most important problems.

The assessments of the alternative solutions formed by experts are subjective and cannot be directly measured in most cases. Therefore classical methods of direct identification of the estimation model are non-applicable. The alternative ones are methods of indirect identification, one of them being the method of comparative identification [1].

General peculiarity of the methods for identification of multifactor assessment model is partitioning of the problem into two parts: the problem of structural identification (generation of the model structure) and parametric identification problem. These problems are solved in series for each version of the model. This makes the procedure of structurally-parametric identification of the model (under high enough dimensionality of tuple of factors characterizing the alternative) very hung us in terms of computing. The prospect to increase the computational efficiency of structurally-parametric identification process presumes:

- algorithmic and computational integration of structural and parametric identification steps into a single process;
- the computational procedure done in such a way that it causes identification of the local models being held in parallel but not in series.

Different approaches to the problem solution are possible, but if we take into account the specifics of the examined then the use of the artificial neural networks appliance (ANN) as a tool turns out to be most prospective.

Problem statement

Let us have a bounded set of alternate solutions $X = \{x_1, x_2, \dots, x_n\}$. Each alternative $x_i \in X$, $i = \overline{1, n}$ is described by the tuple of partial characteristics (factors) $K(x_i) = \langle k_1(x_i), k_2(x_i), \dots, k_m(x_i) \rangle$, that allow their objective quantitative measuring.

On the basis of the given information analysis an individual is able:

- to choose from X the most preferable decision, for example x_t ;
- to rank all decisions in descending (ascending) order of their preference, i.e. to establish a strict or no strict order, e.g. $x_1 \succ (\geq) \tilde{o}_2 \succ (\geq) \dots \succ (\geq) x_n$ or a partial linear order relation, e.g. $x_1 \succ (\geq) \tilde{o}_2 \sim \tilde{o}_3 \succ (\geq) \dots \succ (\geq) x_n$.

Thereto an individual forms subjective assessment for each specific alternative $x_i \in X$, $i = \overline{1, n}$, that reflects its utility (value). Then according to the utility theory [2], that postulates existence of some scalar quantitative assessment for preference of any alternative $x_i \in X$, $i = \overline{1, n}$.

The first case can be formalized as the system of the following inequalities:

$$P(x_t) > (\geq) P(x_i), \quad \forall i \neq t, \quad i = \overline{1, n}, \quad (1)$$

the second accordingly:

$$P(x_1) > (\geq) P(x_2) > (\geq) \dots > (\geq) P(x_n)$$

or

$$P(x_1) > (\geq) P(x_2) = P(x_3) > (\geq) \dots > (\geq) P(x_n), \quad (2)$$

where $P(x_j)$ is an unknown scalar assessment to evaluate utility of the alternative. In this connection we find it necessary to construct a mathematical model, model of generalized utility $P(x_j)$ of a decision maker's individual choice.

The selection of ANN architecture to solve the problem of multifactor assessment model synthesis

Nowadays ANN is viewed as a high-performance special-purpose tool for intellectual problems solving. At that for each class of problems it is necessary to synthesize problem-oriented ANN and to work out an algorithm for specific problem solution.

In most cases for ANN architecture synthesis it is presumed that the model structure is uniquely defined. It means that architecture of ANN that implements the model structure is also fixed and during the process of training only its parametric adaptation takes place. This process is similar to parametric identification of a mathematical model.

Besides there is a big class of indirect-analogy models that approximate a functional model with some polynomials or rows containing considerable nonlinearities. When these models are realized with the help of ANN in general case two problems – realization of nonlinearities and structural adaptation of ANN in the process training.

Solving nonlinear approximation problems with the help of neural nets constructed on classic artificial neurons (AN) of a perceptron type, ADALINE etc. [3] required nonlinearities can be realized with the help of activation functions. It leads to a necessity to use nonlinear methods use training (i.e. to define not only synaptic weights w_i , $i = \overline{1, n}$, but also parameters of nonlinear activation functions), that have low rate of convergence and are ponderous in terms of computing. The alternative for classic ANN are special-purpose networks called functionally related [3].

The general theoretical basis for construction of such a type of networks is the hypothesis [4] that dimension increase of variables input space permits to transform linearly inseparable in space R^n set to linearly separable in space R^m , where $m \gg n$. Functionally it means that input variables $X = \langle x_1, x_2, \dots, x_n \rangle$ are subjected to necessary linear conversion $\varphi_i(X)$ and the results are examined as new complementary variables. At this expense expansion of variables input space is done and a nonlinear input function is transformed into linear by synaptic weights (parameters). Thus a transformation function of the following type is realized:

$$Y = \sum_{i=1}^m w_i \varphi_i(X) \quad (3)$$

This approach allows handling operations of training (parameters identification) nonlinear operators and synaptic weights.

Different types of function φ_i can be used, though it was the polynomial extension realizing Kolmogorov-Gabor multinomial [5], i.e. transformation that was most widely spread:

$$y_j = w_{j0} + \sum_{i=1}^n w_{ji} x_i + \sum_{i_1=1}^n \sum_{i_2=i_1}^n w_{ji_1 i_2} x_{i_1} x_{i_2} + \dots \\ + \sum_{i_1=1}^n \sum_{i_2=i_1}^n \dots \sum_{i_l=i_{l-1}}^n w_{ji_1 i_2 \dots i_l} x_{i_1} x_{i_2} \dots x_{i_l} = w_j^T \varphi(X). \quad (4)$$

This form of ANN has the name of a polynomial.

As it is shown in [6] a model of multifactor assessment is well approximated with Kolmogorov-Gabor polynomial. That is why polynomial ANN is most suitable for solving of the parametric identification problem for a model. But it is also necessary to solve the problem of structural identification of the model. As a result, we have to define the structure of the model having optimal complexity [5] by the minimum error criterion. The specifics of the problem lies in the fact that information about values of alternatives preferences is given not in a quantitative form, but as a system of comparative inequalities of type (1) or (2). Later on, without a loss of generality, let us consider that an individual indicated just the most preferable alternative, i.e. the situation is examined that can be formalized as a system of inequalities of type (1). In this case the model quality can be assessed just by quantity of allowed inequalities (1). Any model that meets all the inequalities is the solution to the problem. There can be quite a great number of such models varying in complexity and parameters values of polynomial approximant (4). Let us call all models of multifactor assessment that meet the whole set of inequalities (1) equivalent models. Besides, we should choose a unique model from the set of equivalent ones. The selection criterion is a minimum of model complexity, i.e. the quantity of tenants and the rank of polynomial approximant (4). To solve this problem different methods can be used. For example, a method of step-by-step complication that can be implemented with the help of functionally related ANN [3].

The main disadvantage of this method is the necessity to use ANN with a large amount of adjustable parameters that causes serious problems connected to the pace of ANN training even while using algorithms with the optimal operation speed.

The alternative method to the method of step-by-step complication of the structure for solving problems demanding not only parametric but also structural ANN training is a group method of data handling (GMDH) [7]. This method allows decreasing the dimensionality of a parametric training problem fundamentally.

GMDH implementation with the help of ANN is based on the use of N-ADALINE (N-A) formal neuron [8]. A scheme of ANN realizing GMDH is given in figure 1.

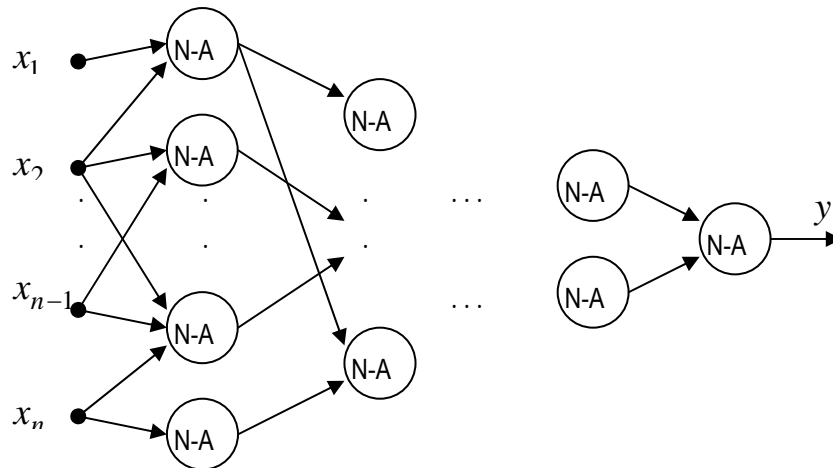

Figure 1. GMDH-neural network

When solving the problem of structurally-parametric synthesis of the multifactor assessment problem with the help of GMDH it can be found that several equivalent models are obtained as output. A unique model is chosen according to the minimal complexity criterion.

ANN training for synthesis of the multifactor assessment model

On solving the structurally-parametric identification problem for the multifactor assessment model, the initial information is given as a system of comparative inequalities (1) that allows to realize the training procedure with a teacher.

The use of the methodology of variables set increase allows us to obtain the ANN structure that is linear by parameters and thereby excludes the necessity of the nonlinear training.

The criterion of the model quality representing the quantity of allowed comparative inequalities (1) is discrete and non-differentiable, i.e. for training only it is possible to use methods of the zero order.

The problem of ANN linear training (defining the value of the synaptic weights) is formally reduced to a problem of parametric identification at a stipulated model structure. This problem is analyzed in detail in [9,10] where it is shown that taking into account the peculiarities of the problem of multifactor assessment model synthesis, it is appropriate to use a method of Chebyshev point estimation, midpoint technique and genetic algorithms for parametric identification and correspondingly for ANN training. The advantage of the first two methods consists in the fact that their realization is based on the standard algorithms of linear programming. But they define only one solution (point solution) from some accessible region. In contrast to this a genetic algorithm allows to determine the set of equivalent by criterion of inequalities satisfaction models (1).

As an alternative to genetic algorithms for equivalent models determination we suggest to use random search technique [11], a coordinate wise descent method or Gauss-Seidel method [12]. At that to increase computing efficiency Chebyshev point or midpoint can be used as a starting one.

An algorithm for solving the problem of structurally parametric identification of the multifactor assessment model with the help of ANN

With a view to describe the algorithm obviously and simply we will examine the solution of the problem of multifactor assessment synthesis of the alternatives x_i , $i = \overline{1, n}$ in the situation when each of them is characterized by four normalized values of the partial criteria $K(x_i) = \{k_1(x_i), k_2(x_i), k_3(x_i), k_4(x_i)\}$. In case of any other quantity of characteristics procedure of solution will be similar.

1. Selection of artificial neuron model generating ANN.

In contrast to traditional neural networks with fixed architecture a GMDH-network has a structure that can vary ("grow") during training.

As a formal neuron in this network N-ADALINE (N-A) is used. It represents an adaptive linear associator with two inputs and a nonlinear preprocessor. By means of a preprocessor nonlinear dependences of any complexity can be realized.

As analysis made in [10] showed for the solution of the structurally-parametric identification of the multifactor assessment problem it is advisable to apply a formal neuron N-A as a basis of ANN, realizing a local polynomial of such a type: $y_v = w_{v1}k_t(x_i) + w_{v2}k_p(x_i) + w_{v3}k_t(x_i)k_p(x_i)$.

Schematic sketch of the neuron model is given in figure 2.

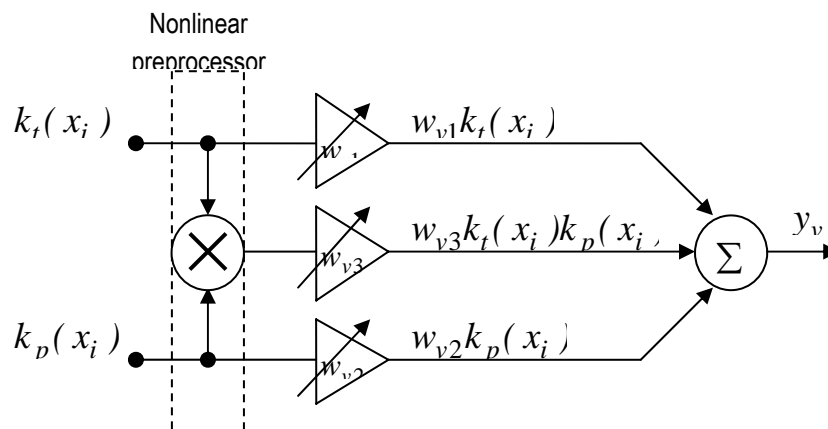

Figure 2. Scheme of N-ADALINE (N-A).

But this does not exclude the possibility to use formal neurons that realize more complicated structures of polynomials.

2. Defining the first layer structure of ANN.

The process of GMDH-network training lies in its configuring starting from the input layer, synaptic weights adjustment for each neuron and increase of layers quantity to achieve a desired value of the model quality criterion.

Figure 3. Scheme of the process of GMDH-network building.

Conclusions

The development of methods for mental work synthesis in general and multifactor assessment models in particular that are not based on subjective expert assessment is of great theoretical and practical value for the theory of multicriteria optimization, multidimensional classification, quality assessment, etc. From this point of view the development of the "objective" identification methods is perspective. One of these methods presented in this paper is the method of comparative structurally-parametric identification of the multifactor assessment model. The use of GMDH-neural network as a tool offers challenges for parallel solving of generation problems (simulated emission) of model structures variants and their parameters identification and at the same time allows using procedures of linear complexity for network training. It allows practically eliminating restrictions from structural complexity and criteria dimensionality of the multifactor assessment model.

Bibliography

- Ovezgeldyev A., Petrov K. Comparative identification of the mental work models. *Journal Cybernetics and system analysis*, №5, 1996, pp. 48-58.
- Neiman J, Morgenshtern O. *Game theory and economic behaviour*. Nauka, Moscow, 1970. P. 124.
- Bodyanskij E., Rudenko O. *Artificial neural networks: architecture, training, implementation*. Teletex, Kharkov, 2004. P. 370.
- Cover T.M. Geometrical and statistical of systems of linear inequalities with applications in pattern recognition. In *IEEE Trans. On Electronic Computers*, 1965, pp. 326 – 334.
- Ivakhnenko A. *Self-organizing systems of recognition and automated management*. Tehnika, Kiev, 1969. P. 392.
- Ovezgeldyev A., Petrov K. Assessment and ranking of alternatives under the interval conditions. *Journal Cybernetics and system analysis*, №4, 2005, pp. 148 – 153.
- Ivakhnenko A., Zajchenko Y., Dimitrov V. *Decision making on the basis of self-organization*. Sovetskoe Radio, Moscow, 1976. P. 280.
- Pham D., Liu X. Modeling and Prediction using GMDH Networks of Adalines with Nonlinear Preprocessors. *Journal System Science*, 1994, pp. 1743 – 1759.
- Ovezgeldyev A., Petrov E., Petrov K. Synthesis and identification of multifactor assessment and optimization models. *Naukova dumka*, Kiev, 2002. P. 162.
- Petrov E., Bulavin D., Petrov K. The use of genetic algorithms for the solution of the structurally-identification problem of model of individual multifactor assessment. *Journal Bionics problems*. №60, 2004, pp. 17-27.
- Rastrigin L. *Random search in adaptation process*. Zinatne, Riga, 1973. P. 132.
- Reklejtis G., Rejvindran A., Regsdel K. *Optimization in technology*. Mir, Moscow, 1986. P. 360.
- Ivakhnenko A., Yurachkovskij Y. *Complex systems modelling according to experimental data*. Radio i svyaz, Moscow, 1987. P. 116.

Authors' information

Eduard G. Petrov – Professor. Department of Systems Science, Kharkov National University of Radio Electronics, Lenin Avenue, 14, 61166, Kharkov, Ukraine kpetrov@kharkov.ukrtel.net

Konstantin E. Petrov - Senior lecturer. Department of Applied Mathematics, Kharkov National University of the Internal Affairs, 50-letiya SSSR Avenue, 27, 61080, Kharkov, Ukraine; kept@mail.ru

Tatyana S. Chaynikova - PhD Student. Department of Systems Science, Kharkov National University of Radio Electronics, Lenin Avenue, 14, 61166, Kharkov, Ukraine st@kture.kharkov.ua