

## THE FUZZY-NEURO CLASSIFIER FOR DECISION SUPPORT

Galina Setlak

**Abstract:** *This paper aims at development of procedures and algorithms for application of artificial intelligence tools to acquire, process and analysis various types of knowledge. The proposed environment integrates techniques of knowledge and decision process modeling such as neural networks and fuzzy logic-based reasoning methods. The problem of an identification of complex processes with the use of neuro-fuzzy systems is solved. The proposed classifier has been successfully applied for building one decision support systems for solving managerial problem.*

**Keywords:** *artificial intelligence, artificial neural networks, fuzzy inference systems, classification, decision support.*

**ACM Classification Keywords:** *I. Computing Methodologies, I.2 Artificial Intelligence*

---

### Introduction

---

A managerial decision support system must harness the information embedded in corporate data and apply this information to problem-solving processes of managers. Information systems required by the factories of the future must be capable of managing, maintaining and processing all forms of information required in the factory. Information is considered as being a vital resource of the enterprise because it represents its mind, because it is the basis for decision making and communication and it forms the basis for new designs.

The traditional artificial intelligence systems, mainly based on the symbolic paradigm, showed to be efficient tools for solving exactly and completely stated problems. However, they were ineffective for solving the real life problems that are described or represented by the imprecise, incomplete, uncertain and linguistic knowledge or by large amounts of numerical data collected in databases. The foregoing drawbacks of the symbolic paradigm based artificial intelligence systems have motivated many researches for creating new tools for designing intelligent decision support systems. As a result of those efforts the techniques named "computational intelligence" have been developed. They have been worked out as a joint of three methodologies: artificial neural networks, fuzzy logic and genetic algorithms. The artificial neural networks bring in the resulting system the ability for learning, generalizing and processing large amount of numerical data, the fuzzy logic allows the follow-on systems to represent and process inexact and uncertain information [Zadeh L.A., Kacprzyk J., 1992], and the genetic algorithm - as a global optimization tool - is used for strengthening the learning abilities of the resulting tool [Rutkowska D., M.Pilinski, L. Rutkowski, 1997]. As a result of joining the artificial neural networks (ANN), fuzzy logic, and genetic algorithms we get the system that is a synergistic combination of the three complementary technologies [Takagi H., 2000], [Rutkowska D., 2000].

Neural computing, genetic algorithms, and fuzzy systems are effective ways to deal with complex problems efficiently. Each method handles uncertainty and ambiguity differently, and these technologies can often be blended to utilize the features each, achieving impressive results. A combination of artificial neural networks and fuzzy logic can result in synergy that improves speed, fault tolerance, and adaptive ness. Fusion of neural networks and fuzzy inference systems have attracted the growing interest of researchers in various scientific and engineering areas due to the growing need of intelligent decision support systems to solve the real world problems. There are many real-world applications of intelligent systems integration [Takagi H., 2000], [Li S.,

2000], [F. Wong, 1992], [D.Nauck, F. Klawonn, R.Kruse, 1997]. Each intelligent system can be a valuable component in a decision support system in which each technology can be used in series or in parallel. For instance, the neural network can identify classes of membership function for the fuzzy system [Jang R., Sun C.T., Mizutani E., 1997], [Takagi H., 2000]. The genetic learning method can perform rule discovery in large databases, with the rules fed into the conventional expert system [Takagi H., 2000].

There are two directions of researches on systems that are built as a combination of neural networks and fuzzy logic based systems. The first one gives as results so-called fuzzy neural networks build of fuzzy neurons [Rutkowska D., M.Pilinski, L.Rutkowski, 1997]. The results of the second research course are neuro-fuzzy systems that use the artificial neural networks within the fuzzy logic systems framework. The most advanced types of the neuro-fuzzy systems are hybrid ones [Li S., 2000], [Rutkowska D., 2000].

The paper presents the neuro-fuzzy technologies which can be used for designing the rule-based intelligent decision support systems. In the paper a connectionist neuro-fuzzy system designed for classification problems is presented. The proposed classifier has been successfully applied for building one decision support systems for solving managerial problem. Example of classification problems solved by means of this hybrid intelligent system is illustrated.

### The Neuro-Fuzzy Method for Knowledge Modelling

Neural Networks can be used in constructing fuzzy inference systems in ways other than training. They can also be used for rule selection, membership function determination and in what we can refer to as hybrid intelligent systems.

Fuzzy systems that have several inputs suffer from the curse of dimensionality. In this paper will investigate and apply the Takagi-Hayashi method [Takagi H., Hayashi I., 1991] for the construction and tuning of fuzzy rules, this is commonly referred to as neural network driven fuzzy reasoning – NDF – method (see Fig.1). The NDF method is an automatic procedure for extracting rules and can greatly reduce the number of rules in a high dimensional problem, thus making the problem tractable.

The NDF method performs three major functions:

- Partitions the decision hyperspace into a number of rules. It performs this with a clustering algorithm.
- Identifies a rule's antecedent values (left hand side - LHS membership function). It performs this with a neural network.
- Identifies a rule's consequent values (right hand side - RHS membership function) by using a neural network with supervised training. This part necessitates the existence of target outputs.

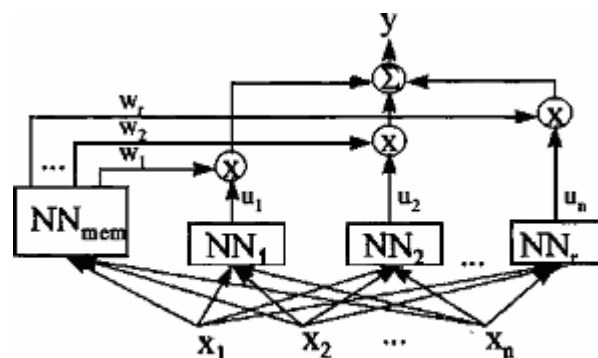

Fig.1. Neural Network Driven Fuzzy Reasoning [Takagi H., Hayashi I., 1991].

The above block diagram represents the NDF method of fuzzy rule extraction. This method uses a variation of the Sugeno fuzzy rule:

$$\text{IF } x_1 \text{ is } A_1 \text{ AND } x_2 \text{ is } A_2 \text{ AND } \dots \text{AND } x_n \text{ is } A_n \text{ THEN } y=f(x_1, x_2, \dots, x_n), \quad (1)$$

where  $f(\cdot)$  is a neural network model rather than a mathematical function. This results in a rule of the form:

$$\text{IF } x_1 \text{ is } A_1 \text{ AND } x_2 \text{ is } A_2 \text{ AND } \dots \text{AND } x_n \text{ is } A_n \text{ THEN } y=NN(x_1, x_2, \dots, x_n). \quad (2)$$

The  $NN_{mem}$  calculates the membership of the input to the LHS membership functions and outputs the membership values. The other neural networks form the RHS of the rules. The LHS membership values weigh the RHS neural network outputs through a product function. The altered RHS membership values are aggregated to calculate the NDF system output. The neural networks are standard feed forward multilayer perceptron designs.

The following 4 steps implement the NDF method. The NDF method also implements methods for reducing the neural network inputs to a small set of significant inputs and checking them for overfitting during training.

Step 1: The training data  $x$  is clustered into  $r$  groups:  $R^1, R^2, \dots, R^s \{s=1,2,\dots,r\}$  with  $n_t^s$  terms in each group. Note that the number of inference rules will be equal to  $r$ .

Step 2: The  $NN_{mem}$  neural network is trained with the targets values selected as:

$$w_i^s = \begin{cases} 1, & x_i \in R^s \\ 0, & x_i \notin R^s \end{cases} \quad i=1,2,\dots, n_t^s, S=1,2,\dots,r. \quad (3)$$

The outputs of  $NN_{mem}$  for an input  $x_i$  are labeled  $w_{is}$ , and are the membership values of  $x_i$  to each antecedent set  $R^s$ .

Step 3: The NNS networks are trained to identify the consequent part of the rules. The inputs are  $\{x_{i1}^s, x_{i2}^s, \dots, x_{im}^s\}$ , and the outputs are  $y_s, i=1,2,\dots,n_t$ .

Step 4: The final output value  $y$  is calculated with a weighted sum of the  $NN_s$  outputs:

$$y_i = \frac{\sum_{s=1}^r \mu_{A^s}(x_i) \cdot \{U_s(x_i)\}_{inf}}{\sum_{s=1}^r \mu_{A^s}(x_i)}, \quad i=1,2,\dots,n_t, \quad (4)$$

where  $u_s(x_i)$  is the calculated output of  $NN_s$ .

---

### The Neuro-Fuzzy Classifier for Decision Support

---

Neural networks are widely used as classifiers; see e.g. [Jang R., Sun C.T., Mizutani E., 1997], [Moon Y.B., Divers C.K., and H.-J.Kim, 1998], [Takagi H., 2000]. Classification and clustering problems has been addressed in many problems and by researchers in many disciplines like statistics, machine learning, and data bases. The basic algorithms of the classification methods are presented in [D.Nauck, F. Klawonn, R.Kruse, 1997], [Setlak G., 2004]. The application of the clustering procedure can be classified into one of the following techniques [Jang R., Sun C.T., Mizutani E., 1997] partition in which a set is divided into  $m$  subsets, when  $m$  is the input parameter:

- hierarchical form trees in which the leaves represent particular objects, and the nodes represent their groups. The higher level concentrations include the lower level concentrations. In terms of hierarchical

methods, depending on the technique of creating hierarchy classes (agglomerative methods and divisive methods);

- graph-theoretic clustering,
- fuzzy clustering,
- methods based on evolutionary methods,
- methods based on artificial neural networks.

In this work two approaches have been applied to clustering of parts and assembly units. As basic method it was used Self Organizing Map (SOM) of Kohonen, a class of unsupervised learning neural networks, to perform direct clustering of parts families and assembly units. Self Organizing Maps are unsupervised learning neural networks which were introduced by T. Kohonen [Kohonen T., 1990] in the early '80s. This type of neural network is usually a two-dimensional lattice of neurons all of which have a reference model weight vector. SOM are very well suited to organize and visualize complex data in a two dimensional display, and by the same effect, to create abstractions or clusters of that data. Therefore neural networks of Kohonen are frequently used in data exploration applications [Kohonen T., 1990], [Takagi H., 2000]. SOM have been applied to classification of machine elements in group technology [Setlak G., 2004].

The other approach applies fuzzy logic and fuzzy neural systems for classification problems. However, neural networks work as a "black box", which means that they produce classification results but do not explain their performance. Thus, we do not know the rules of classification. Neural network weights have no physical interpretation. Fuzzy and fuzzy neural systems can be employed in order to solve classification problems [Setlak G., 2000]. The neural-fuzzy systems are rule-based systems that realize fuzzy IF-THEN rules. Some of the major works in this area are ANFIS [Jang, 1992], [Jang 1997], NEFCLASS [D.Nauck, F. Klawonn, R.Kruse, 1997], CANFIS

ANFIS (Adaptive Neuro-Fuzzy Inference System) [Jang, 1992], [Jang R., Sun C.T., Mizutani E., 1997] (Fig.1) is a network-structured adaptive fuzzy inference system which has found various applications including control, system identification, time series prediction, and noise cancellation. A common version of ANFIS uses normalized input fuzzy membership functions, product fuzzification, product inference, sum composition and Sugeno-type linear output functions (and thus needs no defuzzification). The system parameters are tuned using stochastic gradient descent method for the premise parameters and recursive least square method for the consequent parameters.

The CANFIS (Co-Active Neuro-Fuzzy Inference System) model integrates fuzzy inputs with modular neural network to quickly solve poorly defined problems. Fuzzy inference systems are also valuable as they combine the explanatory nature of rules (membership functions) with the power of "black box" neural networks.

Proposed hybrid intelligent system for classification can be presented and is shown in Fig. 2. They make a fuzzy inference based on a collection of fuzzy IF-THEN rules, called the rule base, described as follows:

A neuro-fuzzy system for classification can be presented in the form of the connectionist network shown in Fig. 2. The proposed Neuro-Fuzzy Classifier (NFC) is a hybrid neuro-fuzzy system that

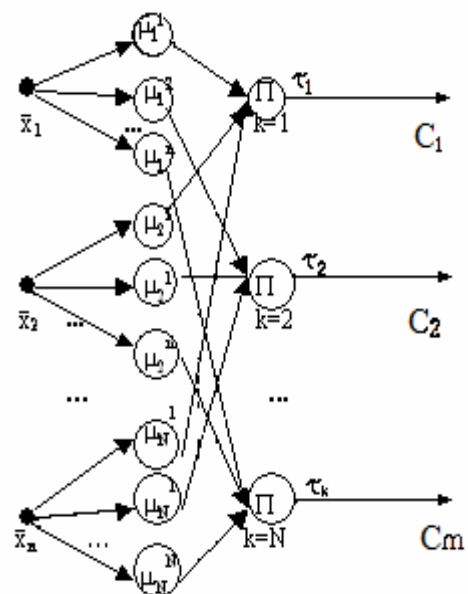

Fig.2. A neuro-fuzzy system for classification

has a feed-forward network-like structure. The structure of the system expresses the fuzzy rules base that models the process of decision-making.

The classifier illustrated in Fig.2 reflects the following fuzzy classification rules:

$$R^{(k)}: \text{ IF } x_1 \text{ is } G_1^k \text{ and } x_2 \text{ is } G_2^k \text{ and } \dots \text{ and } x_n \text{ is } G_n^k \text{ THEN } (x \in C_l) \quad (5)$$

where  $x = [x_1, x_2, \dots, x_n]^T$ , and  $x_i$ , for  $i = 1, 2, \dots, n$ , are linguistic variables,  $G^k$  is fuzzy sets for  $i$ -th input and  $k$ -th fuzzy rule,  $C_l$ , for  $l=1, 2, \dots, m$ , are classes,  $N$  denotes the number of rules  $R^{(k)}$ , for  $k = 1, \dots, N$ .

The crisp input values, presented in Fig.2, constitute the input vector:  $\bar{x} = [x_1, x_2, \dots, x_n]^T$ .

The output values,  $\tau_k$ , for  $k = 1, 2, \dots, N$ , represent degrees of rule activation [6], expressed as follows:

$$\tau_k = \prod_{i=1}^n \mu_i^k(\bar{x}_i), \quad (6)$$

where

$$\mu_i^k(x_i) = \exp\left[-\left(\frac{x_i - \bar{x}_i^k}{\sigma_i^k}\right)^2\right] \quad (7)$$

is the Gaussian membership function, characterized by the center and width parameters,  $\bar{x}_i^k$  and  $\sigma_i^k$ , respectively. The neuro-fuzzy network portrayed in Fig.2 performs a classification task based on the values of  $\tau_k$ , for  $k = 1, \dots, N$ . Each input vector  $\bar{x} = [x_1, x_2, \dots, x_n]^T$  is classified to the class  $C_l$  (where  $l = 1, 2, \dots, m$ ), which is associated with the maximal degree of rule activation, that is  $\max_k \{\tau_k\}$ .

There are five phases of designing the NFC system:

- Each input attribute is described by a number of fuzzy sets;
- The initial fuzzy rules base is determined;
- System training;
- Testing the system against test data;
- Pruning the system – removing “weak”, superfluous fuzzy rules in order improve system’s transparency.

An example of implementing this neuro-fuzzy classifier is given below.

---

### Example: international stock selection

---

The presented hybrid neuro-fuzzy system has been applied for building Intelligent Decision Support System (IDSS). As example of a hybrid neuro-fuzzy system we have chosen a method for deriving a stock portfolio plan.

An international investment company uses a hybrid neuro-fuzzy system to forecast the expected returns from stocks, cash, bonds, and other assets to determine the optimal allocation of assets. Because the company invests in global markets, it is first necessary to determine the creditworthiness of various countries, based on past and estimated performances of key socio-economic ratios, and then select specific stocks based on

company, industry, and economic data. The final stock portfolio must be adjusted according to the forecast of foreign exchange rates, interest rates, and so forth, which are handled by a currency exposure analysis. The IDSS includes the following technologies:

- Expert system. The system provides the necessary knowledge for both country and stock selection (rule-based system).
- Neural network. The neural network conducts forecasting based on the data included in the database.
- Fuzzy logic. The fuzzy logic component supports the assessment of factors for which there are no reliable data. For example, the *credibility* of rules in the rule base is given only as a probability. Therefore, the conclusion of the rule can be expressed either as a probability or as a fuzzy membership degree.

The rule base feeds into IDSS along with data from the database. IDSS is composed of three modules: membership function generator (MFG), neuro-fuzzy inference system (NFIS), and neural network (NN). The modules are interconnected, and each performs a different task in the decision process.

Performance of a IDSS has been tested on the following input data:

- There are three input nodes ( $n = 3$ ):  
 $X_1$  – risk of investment, it is defined by a linguistic term  $G^k$ , such as “high”, “medium”, “low”.  
 $X_2$  – clear profit, also it is defined by a linguistic term  $G^k$ , such as “high”, “medium” and “low”.  
 $X_3$  – period refund of investment, it is defined by a linguistic term  $G^k$ , such as “long”, “medium” and “short”.
- The output values: are three classes  $C_1$ , where  $C_1$  – is defined by a linguistic term “very good investment”,  $C_2$  – “poor investment” and  $C_3$  – “resign”.
- The fuzzy set is characterized by a membership function  $\mu_i^k(x_i): R \rightarrow [0,1]$ . The membership functions for the fuzzy set, are expressed as (7).

Following the procedure described in section 2, the initial shapes of the fuzzy sets describing the input attributes were defined and the initial fuzzy rules base, containing 144 rules, was generated. The NFC method of using neural networks to generate the antecedent and consequent membership functions has been found to be useful and easily implemental with

Table 1. Results of the classification problem obtained using NFC and agglomerative methods

N	Price	Advertising	Volume of sales	Stimulus of sale	Neuro-fuzzy Classifier	Agglomerative methods	Profit
1	385,65	12000	227180	10000	P1	P1	87589967
2	397,24	10000	235090	6000	P1	P1	93371151,6
3	452,20	10000	217340	10000	P4	P4	98261148
4	478,92	12000	261280	8000	P3	P3	125112217,6
5	493,10	10000	184380	5000	P2,P3	P3	90902778
6	526,35	8000	147180	4000	P2	P2	77456193
7	583,24	5000	149300	3000	P2,P3	P2	87069732
8	594,93	5000	156520	4000	P1	P1	93109443,6
9	620,70	5000	121280	2000	P2,P3	P2	75271496
10	634,56	10000	116530	0	P3,P4	P4	73935276,8
11	663,20	2000	102160	0	P2,P3	P3	67750512
12	672,35	0	112510	0	P1,P2,P3	P3	75646098,5

---

## Conclusions

---

The single-layer neural network, proposed in this paper for classification, has the following features:

- Each neuron represents one fuzzy IF-THEN rule.
- The number of neurons equals to the number of rules in the rule base.
- Weights of the neurons have an interpretation concerning parameters of the membership functions of the corresponding neuro-fuzzy system.
- It is easy to modify the network architecture when a rule is added or removed (by addition or removal, respectively, the neuron that represents this rule).

Thus, in contrast to classical neural networks, the network proposed in this paper does not work as a "black box". This network is a rule-based neural network.

Single-layer neural networks can contain many neurons, so it is no problem to increase the number of rules in order to achieve better performance of the classifier. In this way, it is easy to incorporate learning from mistakes [Li S., 2000], by formulating new rules to avoid the mistakes. This method was applied in the classification problems depicted latter.

It is worth emphasizing that, in contrast to classical learning of neural networks, the method proposed in this paper allows the network to work without mistakes (based on the data set) and do not lose its generalization ability.

In the paper we have applied basic soft techniques for extracting rules and classification in a high dimensional managerial problem. The hybrid neuro-fuzzy system briefly presented in the paper was successfully applied for designing intelligent decision support system.

By using several advanced technologies (combination of fuzzy logic and neural networks) it is possible to handle a broader range of information and solve more complex problems. The research conducted proves that fuzzy neural networks are a very effective and useful instrument of implementation of intelligent decision support systems in management.

---

## Bibliography

---

- [Jang, 1992] Jang R.: Neuro-Fuzzy Modeling: Architectures, Analyses and Applications, PhD Thesis, University of California, Berkeley, 1992.
- [Jang R., Sun C.T., Mizutani E., 1997] Jang S.R., Sun C.T., Mizutani E.: Neurofuzzy and Soft Computing, Prentice-Hall, Upper Saddle River 1997, p. 245.
- [Kohonen T., 1990] Kohonen T.: Self-organizing Maps, Proc. IEEE, 1990, 78, NR.9, pp. 1464-1480.
- [Li S., 2000] Li S.: The Development of a Hybrid Intelligent System for Developing Marketing Strategy, Decision Support Systems, 2000, Vol 27, N4,
- [Moon Y.B., Divers C.K., and H.-J. Kim, 1998] Moon Y.B., Divers C.K., and H.-J. Kim: AEWS: An Integrated Knowledge-based System with Neural Network for Reliability Prediction // Computers in Industry, 1998, Vol.35, N2, pp.312-344.
- [D.Nauck, F. Klawonn, R.Kruse, 1997] D.Nauck, F. Klawonn, R.Kruse: Foundations of Neuro-Fuzzy Systems, J.Wiley&Sons, Chichester, 1997.
- [Rutkowska D., 2000] Rutkowska D.: Implication-based neuro-fuzzy architectures.- Applied mathematics and computer science, V.10, N4, 2000, Technical Unieversity Press, Zielona Gora, 675-701.
- [Rutkowska D., M.Pilinski, L. Rutkowski, 1997] Rutkowska D., M.Pilinski, L. Rutkowski: Sieci neuronowe, algorytmy genetyczne i systemy rozmyte, PWN, Warszawa, 1997 r., pp.411.

[Setlak G., 2004] Setlak G.: Intelligent Decision Support System, // LOGOS, Kiev, 2004, (in Rus.), pp. 250.

[Setlak G., 2000] Setlak G.: Neural networks in intelligent decision support systems for management // Journal of Automation and Information Sciences, Kiev, N1, 2000r., pp. 112-119.

[Takagi H., Hayashi I., 1991] Takagi H., Hayashi I.: NN-Driven Fuzzy Reasoning, //International Journal of Approximate Reasoning, 1991, Vol.3, p.1376-1389.

[Takagi H., 2000] Takagi H. Fusion technology of neural networks and fuzzy systems //International Journal of Applied mathematics and computer science, Zielona Gora, 2000, Vol.10, №4, pp.647-675.

[F. Wong, 1992] F. Wong: "Neural Networks, Genetic Algorithms, and Fuzzy Logic for Forecasting," Proceedings, International Conference on Advanced Trading Technologies, New York, July 1992, pp.504-532.

[Zadeh L.A., Kacprzyk J., 1992] Zadeh L.A., Kacprzyk J.(ed.): Fuzzy logic for the Management of Uncertainty, Wiley, New York, 1992, p. 492.

---

### Authors' Information

---

Galina Setlak – Ph.D., D.Sc, Eng., Associate Professor, Rzeszow University of Technology, Department of Computer Science , W. Pola 2 Rzeszow 35-959, Poland, Phone: (48-17)- 86-51-433, [gsetlak@prz.edu.pl](mailto:gsetlak@prz.edu.pl)