

SMART PORTABLE TESTER FOR BIRD FLU EXPRESS-DIAGNOSTICS: PRINCIPLES OF DESIGN

Oleksandr Palagin, Volodymyr Romanov, Mykola Starodub, Igor Galelyuka,
Oleksandra Skrypnyk, Kyryl Skyba

Abstract: In the V.M. Glushov Institute of Cybernetics of National Academy of Sciences of Ukraine in collaboration with O.V. Palladin's Institute of Biochemistry of National Academy of Sciences of Ukraine the smart portable device for express-diagnostics of acute viral infections, including bird flu, is designed. The device is based on the effect of surface plasmon resonance. The principles of device are described in the article.

Keywords: bird flu, portable device, biosensor, surface plasmon resonance, acute viral infection.

ACM Classification Keywords: J.3 Life and Medical Sciences – Medical information systems

Conference: The paper is selected from Sixth International Conference on Information Research and Applications – i.Tech 2008, Varna, Bulgaria, June-July 2008

Introduction

Ukraine and others countries suffer from spreading of retroviral infection and others dangerous infectious diseases, including Newcastle disease, bird flu etc. At the same time laboratories for express-diagnostics of listed diseases are absent in the areas of pandemics. This diagnostics is made to order in well-found laboratories, witch are situated in several large cities or others countries. As a result of untimely detection of epidemic every country incurs large losses, and not only animals' lives, but also people's lives are under thread in areas of epidemic.

Taking into account the necessity of medicine in the infectious diseases express-diagnostics of people and animals, such as bird flu, anthrax, tularemia, Newcastle disease and others, the urgent problem now is development, creating and experimental tests of portable biosensor device with GSM-connection and GPS-system for express-diagnostics of acute infectious diseases (including ones of retroviral origin) in the field conditions with transmission of infectious disease place and character by radio-channel.

Because of modern achievements of microelectronics and informatics means it is possible now for the first time in Ukraine to create enough cheap portable biosensor devices on the base of surface plasmon resonance (SPR) for monitoring of especially dangerous infection agents in the field conditions of exploitations. These devices don't need qualified personnel for exploitation. There are no portable industrial devices for express-diagnostics of bird flu and others similar acute viral infections are absent in Ukraine and in the world (see table 1).

Problem description

Taking into account the necessity of wide using of biosensor devices for express-diagnostics of animals and people illness for acute viral infection, such as bird flu, in the places of possible pandemic spreading, in the V.M. Glushkov Institute of Cybernetics of National Academy of Sciences of Ukraine (NASU) in collaboration with O.V. Palladin's Institute of Biochemistry of NASU there is designed of enough simple and cheap biosensor device on the base of SPR for this goal.

Table 1. Comparative parameters of biosensor devices for bird flu diagnostics

Device name	<i>Vereflu</i>	<i>Biosensor for bird flu diagnostics</i>	<i>Interference biosensor</i>	<i>Biosuplar</i>	<i>Biacore 3000</i>	<i>Biosensor on the base of SPR</i>
Developer	Laboratory "Veredus" (Singapore), company "ST Microelectronics"	Institute of bioengineering and nanotechnology, Institute of genome, Institute of biomolecular and cellular biology (Singapore), company "ST Microelectronics"	Biophysical engineering group from University of Twente city, Holland	Germany, www.micr o-system.de	Sweden, www. biacore.co m	Institute of Cybernetics of NASU, Institute of Biochemistry of NASU, Ukraine
Portable	Yes	Yes	Yes	No	No	Yes
Development stage	Experimental	Experimental	Experimental	Laboratorial	Laboratorial	Experimental
Test time length	2 hours	30 minutes	2 minutes	1 hour	1 hour	2-5 minutes
Cost	150 USD	Not determined	Not determined	10 000 USD	30 000 USD	300 USD

As we can see from table, portable biosensor devices for express-diagnostics of bird flu or other acute infectious diseases viruses are until now on the development stage. It is evidence of urgency of chosen direction.

The features of new biosensor device are the following:

- direct analysis without using reagents;
- express-diagnostics during several minutes;
- analysis with using only 1-2 drops of blood;
- price of analysis no more than 1-2 USD;
- resolution is enough to detect the presence of diagnostic-significant immune components, for example ones typical for bird flu, in threatening quantity in the people or animals blood;
- small sizes and weight (less 0,5 kilogram);
- battery supply;
- field application, for example in the places of gathering of migrant birds or in the places of dearch of poultry;
- processing of analysis data, to show analysis results on build-in display and transfer them by radio-channel to regional medical institutions;
- simple use;
- high productivity – tens of analysis per hour;
- low cost.

Principles of design

The device belongs to area of biological substances researches by analysis of SPR curve shift, size of which is proportional to mass or concentration of biological substance in the research liquid. The device is intended for the express-diagnostics of acute infectious diseases, including bird flu, in the field conditions and data transferring by radio-channel from places of epidemic to medical institutions. In the device it is used SPR effect, according to which the size of SPR curve shift or, it is the same, the change of refractive index is proportional to the antibodies concentration in the ill bird blood, which is placed on the sensitive surface of the device. The device sensitive surface is covered by layer of analyte, which contains special proteins of bird flu (antigens). Ill bird antibodies interact with these proteins.

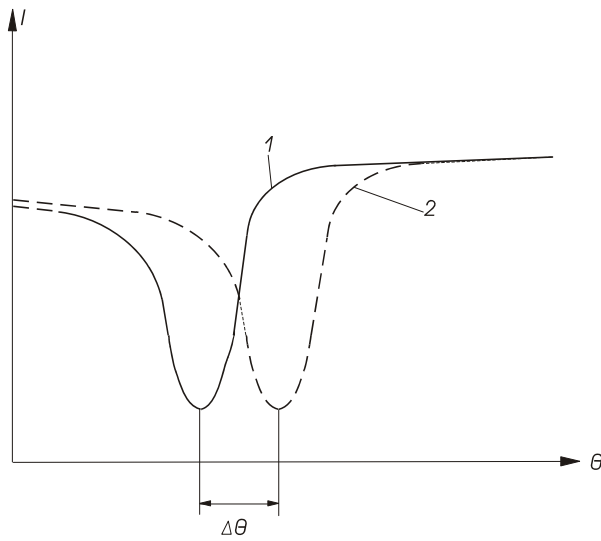

Figure 1. Resonant characteristics of SPR sensor:

- 1 – with absence of analyte molecules on receptor layer;
- 2 – with presence of analyte molecules on receptor layer.

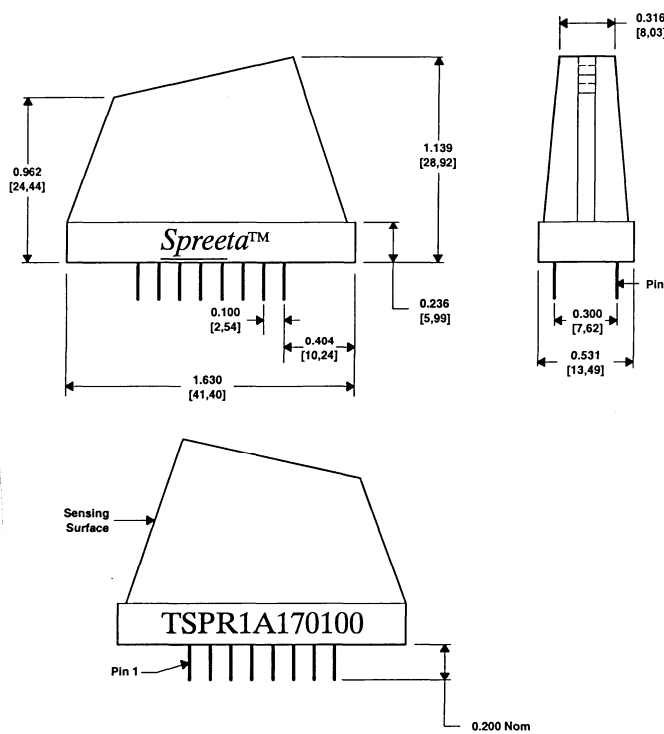

Figure 2. Surface appearance of laboratory-on-crystal *Spreeta*

Because of “antigen-antibody” reaction antibodies, if they are present in the bird blood, combine with device sensitive surface, what causes shift of SPR curve (see fig. 1). Data about presence or absence of antibodies, which are got by means of device in the field conditions, are transferred by radio-channel to the medical center.

In the offered device there is used, such called, laboratory-on-crystal Spreeta TSPR 1A170100 (see fig. 2), which is manufactured by company Nomadics, Inc on the base of SPR [Nomadics, Ti]. Spreeta contains prism with sensitive surface. The prism has build-in LED, mirror, photodetectors and logic units. LED exit is connected by means of optical line to sensitive surface of prism, sensitive surface of prism is connected by means of optical line to the mirror, which has optical connection with ruler of photodetectors, exit of which is exit of Spreeta. LED lights up sensitive surface and light beam beats off to mirror. Then reflected beam falls on photodetectors of Spreeta (see fig. 3).

Laboratory-on-crystal Spreeta converts the SPR curve shift to discrete pulses. These pulses are digitizing, processing in the portable device and then data are transferred by radio-channel.

The functional diagram of designed portable device is shown on the fig. 4, which includes Spreeta sensors, analog-digital converter, microprocessor unit for electronic processing, display and radio-channel.

Analysis data are transferred from device to the medical center or laboratory by means of radio-channel. As radio-transmitter it is used the original unit, which is developed by company "VD MAIS" [vdmais]. Besides data analysis also information about place of analysis is transferred by means of radio-channel. For this goal it is used GPS-system, which is built in the radio-transmitter. Principle of operation is based on the transferring all data through radio-channel (by means of GSM-technology) directly to the Internet, and then to the server of medical organization.

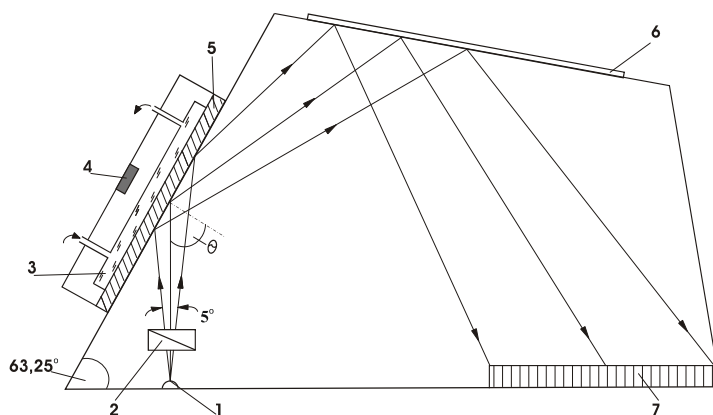

1 – LED; 2 – polarizer; 3 – flow-through cell; 4 – thermistor; 5 – sensitive surface; 6 – mirror; 7 – photodetectors

Figure 3. Optical scheme of laboratory-on-crystal *Spreeta*

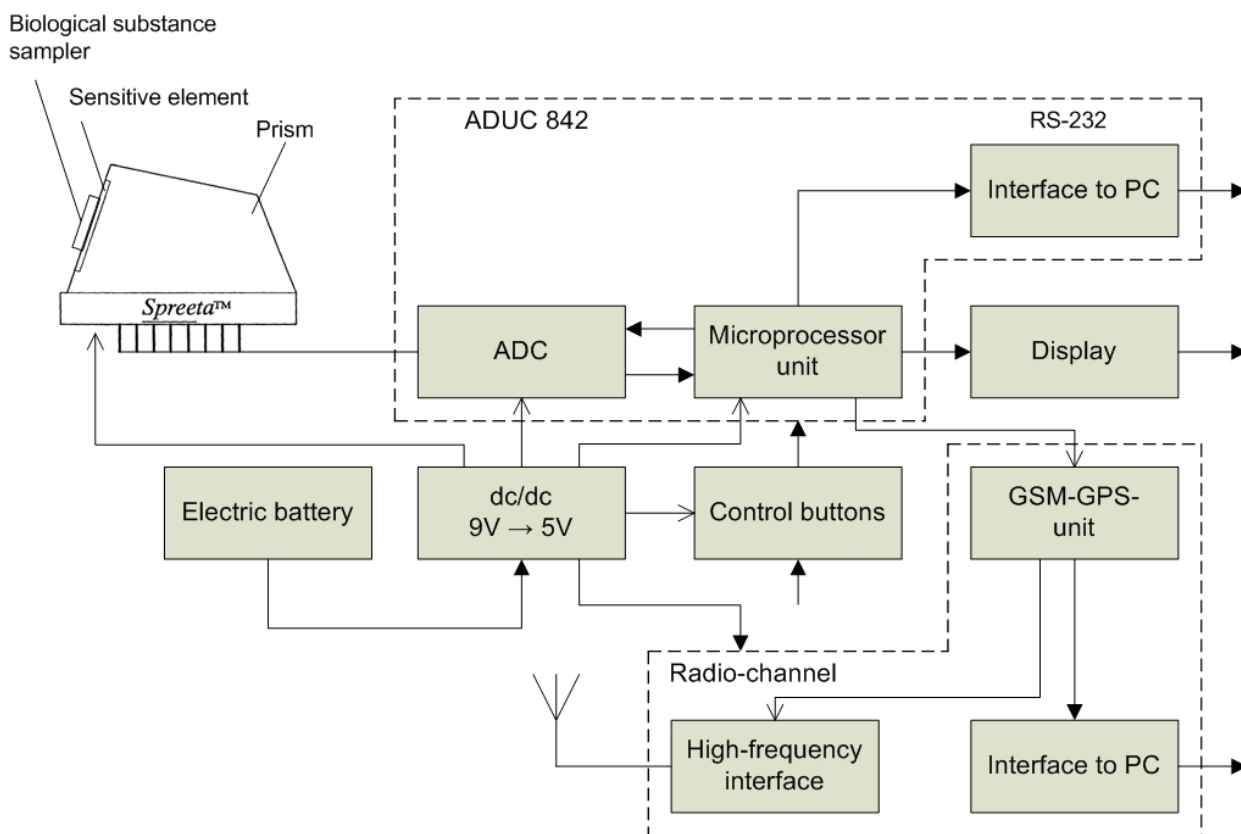

Figure 4. Functional diagram of the device

Conclusions

- as a result of made review of scientific research materials and documentation on mass electronic components and systems we can make next conclusion – off-the-shelf portable devices for express-diagnostics of acute viral infection, including bird flu, are absent on the world market. Now there are fulfilled several enough prospective researches in the some leading universities of the world and conducted tests of experimental samples;

- present off-the-shelf laboratorial devices are not suitable for mass using in the places of pandemic and, in addition, they are very expensive and need high qualified personnel for exploitation;
- specialist of V.M. Glushkov Institute of Cybernetics of NASU together with specialists of O.V. Palladin's Institute of Biochemistry of NASU developed original portable biosensor device with radio-channel for express-diagnostics of acute viral infections [Palagin, 2007; Patent, 2006], including bird flu [Romanov, 2007; Starodub, 2007];
- this time experimental sample of device is under investigation.

Bibliography

[Nomadics] <http://www.nomadics.com/>.

[Ti] <http://www.ti.com>.

[vdmais] <http://vdmais.kiev.ua>.

[Palagin, 2007] Palagin O., Romanov V., Starodub M., Brayko Yu., Galelyuka I., Imamutdinova R., Sarahan Ye. Portable Devices for Express-Diagnostics of Photosynthesis, Viral Infections and Mycotocsicosis // Proceeding of the IV International scientific-practical conference "Urgent question and organizational-lawful aspects of Ukraine-China collaboration in the high technologies field" – Kiev, Ukraine. – 2007, 10 october. – P. 135–138.

[Patent, 2006] Patent of Ukraine № 18099. Device for express-diagnostics of infectious diseases // Romanov V.O., Starodub M.F., Galelyuka I.B. Romanova O.V., Starodub V.M. Bul. № 10 from 16.10.2006.

[Romanov, 2007] O. Palagin, V. Romanov, I. Galelyuka, M. Kachanovska. Virtual Laboratory for Computer-Aided Design of Biosensors // Computing. – 2007, Vol. 6, Issue 2. – P. 68–76.

[Starodub, 2007] Starodub M.F., Romanov V.O., Kochan R.V., Sachenko A.O., Kochan O.V. Implementation of SPR-Biosensors for Express-Diagnostics of Acute Viral Infection and Mycotocsicosis // Proceedings of the IEEE International Workshop on Medical Measurements and Applications MeMeA 2007, Warsaw – Poland, May 4–5, 2007.

Authors' Information

Oleksandr Palagin – *depute-director of V.M. Glushkov's Institute of Cybernetics of National Academy of Sciences of Ukraine, Academician of National Academy of Sciences of Ukraine, Doctor of technical sciences, professor; Prospect Akademika Glushkova 40, Kiev–187, 03680, Ukraine; e-mail: palagin_a@ukr.net*

Volodymyr Romanov – *head of department of V.M. Glushkov's Institute of Cybernetics of National Academy of Sciences of Ukraine, Doctor of technical sciences, professor; Prospect Akademika Glushkova 40, Kiev–187, 03680, Ukraine; e-mail: dept230@insyg.kiev.ua*

Mykola Starodub – *head of department of O.V. Palladin's Institute of Biochemistry of National Academy of Sciences of Ukraine; Leontovycha str., 40, Kiev–30, 01601, Ukraine; e-mail: nstarodub@yahoo.com*

Igor Galelyuka – *research fellow of V.M. Glushkov's Institute of Cybernetics of National Academy of Sciences of Ukraine; Prospect Akademika Glushkova 40, Kiev–187, 03680, Ukraine; e-mail: dept230@insyg.kiev.ua*

Oleksandra Skrypnyk – *software engineer of V.M. Glushkov's Institute of Cybernetics of National Academy of Sciences of Ukraine; Prospect Akademika Glushkova 40, Kiev–187, 03680, Ukraine; e-mail: dept230@insyg.kiev.ua*

Kyryl Skyba – *M2M expert of company "VD-MAIS", Gylyanska str., 29, Kiev, 01033, Ukraine; e-mail: m2m@vdmais.kiev.ua*